

Afghanistan Research and Evaluation Unit
Issues Paper Series

Decisions, Desires and Diversity: Marriage Practices in Afghanistan



Deborah J. Smith

February 2009



Afghanistan Research and Evaluation Unit
Issues Paper Series

Decisions, Desires and Diversity: Marriage Practices in Afghanistan

Deborah J. Smith



Funding for this research was provided
by the European Commission (EC).

February 2009

Editor: Meredith Lewis for AREU

Layout: Mia Bonarski

Cover Photograph: AINA Photo Agency

© 2009 Afghanistan Research and Evaluation Unit. All rights reserved. No part of this publication may be reproduced, stored in a retrieval system or transmitted in any form or by any means, electronic, recording or otherwise without prior written permission of the publisher, the Afghanistan Research and Evaluation Unit. Permission can be obtained by emailing areu@areu.org.af or by calling +93 799 608 548.

About the Author

Deborah J. Smith is the Senior Research Manager for Gender and Health at the Afghanistan Research and Evaluation Unit. Since joining AREU in February 2006, Deborah has managed a research portfolio that includes: customary law and community-based dispute resolution; the representation of women's interests in the wolesi jirga; gender mainstreaming in government ministries; the problem use of psychotropic drugs; and family dynamics and family violence. Previously, Deborah worked at the London School of Hygiene and Tropical Medicine where she conducted health policy research in Malawi and Zambia. She has a PhD from the London School of Economics and Political Science, for which she conducted field research on gender issues in Rajasthan, India.

About the Afghanistan Research and Evaluation Unit

AREU is an independent research organisation based in Kabul. AREU's mission is to conduct high-quality research that informs and influences policy and practice. AREU also actively promotes a culture of research and learning by strengthening analytical capacity in Afghanistan and facilitating reflection and debate. Fundamental to AREU's vision is that its work should improve Afghan lives.

AREU was established in 2002 by the assistance community working in Afghanistan and has a board of directors with representation from donors, United Nations and other multilateral agencies, and non-governmental organisations. Current funding for AREU is provided by the European Commission (EC), the United Nations High Commissioner for Refugees (UNHCR), the United Nations Children's Fund (UNICEF), the United Nations Development Fund for Women (UNIFEM), the World Bank and the governments of Denmark, Japan, Norway, Sweden, Switzerland and the United Kingdom.

Acknowledgements

The research for and writing of this report would not have been possible without the assistance, support and dedication of many people.

A huge debt of gratitude is owed to the residents of the villages and urban areas where the research was conducted for the hospitality they extended to members of the research team, for their patience and candour in recounting their families' stories and explaining the details of their lives, for their willingness and ability to understand and support the objectives of the research and for giving their precious time given to speak with and assist the research team. In the re-telling and analysis of their stories, I hope I have, at the least, done justice to the information they shared with the research team.

This research would not have been possible without the diligence, dedication and perseverance of the members of the research team who collected the data in the field: in Bamyan – Ali Hassan Fahimi, Sakina Sakhi, Mohammad Hassan Wafaey and Zara Nezami; in Herat – Asila Sharif Sadiqi, Homa Salehyar, Faqrullah Niksad and Azizullah Royesh; in Kabul – Sakhi Frozish, Leena Waheedi, Yama Qasimyar and Saghar Wafa; and in Nangarhar – Hanifa Gulmiran, Abdul Jalil Nooristani, Abdul Manon Sadiqi and Parwana Wafa. Those team members who continued to work with AREU after the completion of the fieldwork should also be recognised for their analytical insights and ongoing attention to detail.

The partnership between AREU and the AIHRC was an essential component to completing this work. I would in particular like to acknowledge and thank all those staff from the regional offices in Bamyan, Herat and Nangarhar for the hospitality and assistance they offered my colleagues and I on our frequent visits.

The support offered by both Orzala Ashraf and Yasmin Damji toward the end of the data collection period was essential in ensuring a complete and detailed set of data. A special thank you goes to Yasmin for designing and drawing up the family maps. Eileen Summers is acknowledged for the invaluable support she gave the research team in coping with conducting research on what, at times, can be a very distressing subject. I am grateful to the anonymous reviewers for the comments and insights they offered on this report.

Finally, I would like to express my gratitude and appreciation to Paula Kantor for her unending support throughout the course of this research.

Deborah J. Smith
January, 2009

Table of Contents

Acronyms	ii
Glossary	iii
Executive Summary	ix
Part 1: Theoretical, Methodological and Research Site Context	xii
1. Introduction	xii
2. Methodology	5
3. Research Sites	9
Part 2: Decision-Making Processes About Marriages	14
4. Gender, Generation and Status: Roles of Men and Women in Marriage Decisions	16
5. Choice and Force – Role of Children in Marriage Decisions	23
6. The Marriage Decision – Fear and External Pressures	33
Part 3: Marriage Practices	37
7. Exchanging Daughters for a Bride, Exchanging Daughters for Money	38
8. Polygamous Marriage	46
9. Conclusions and Recommendations	57
References	64
Recent Publications from AREU	67

Acronyms

AIHRC	Afghanistan Independent Human Rights Commission
AREU	Afghanistan Research and Evaluation Unit
NGO	non-government organisation

Glossary

ailaq	spring and summer habitat and pasture land located outside main village
ambagh	co-wife
bad	a practice in which a girl is given in marriage to an opposing family in order to resolve a dispute or as a form of compensation
badal	a marriage conducted by exchanging two girls for each other
bota	bushes used for fuel for cooking and heating
brastan	quilts
chopan	shepherd
daya	traditional birth attendant
deseterkhon	cloth which is laid on the floor for eating from
jerib	unit of land measurement: 1 jerib equals roughly one fifth of a hectare
kafeer	non-Muslim
khanadamad	the situation where a man lives in his father-in-law's house
khostagary	marriage proposal
malik	community leader (usually in a rural area)
mordagaw	a man who sells women for sex; a pimp
mufti	religious scholar
nang	shame
nasaka	used to describe brothers and sisters who only share one biological parent or a step-parent— for example, "nasaka mother"
nekah	the marriage contract, read by the mullah, and the main part of the marriage ceremony that confirms a couple is married
qawm	a kinship group that can range considerably in size and scope, often translated as tribe or clan
waliswali	district; often used to refer to the central town in a district
wolesi jirga	the lower house of the National Assembly of Afghanistan

Executive Summary

Decisions, Desires and Diversity is one of a series of reports by the Afghanistan Research and Evaluation Unit examining family dynamics and family violence in Afghanistan. It explores the many different ways in which marriages are decided on and practised in Afghan families. Respondents interviewed during the research frequently talked about decision-making in relation to marriage and marriage practices, and it was for this reason that the topic of marriage practices emerged as an important aspect of analysing family dynamics. Indeed, the institution of marriage is central to Afghan social life – regardless of region, ethnicity or kinship group (*qawm*).

Data for this study, which is qualitative in nature, was collected between June 2006 and February 2007 in rural and urban areas of four provinces of Afghanistan: Bamyan, Herat, Kabul and Nangarhar. This resulting report is divided into three parts: Part 1 provides the conceptual, methodological and research site context; Part 2 discusses the decision-making processes in relation to the marriages of a family's children; and Part 3 discusses common marriage practices, including exchange marriages (*badal*), bride price and polygamy.

This report will be of use to:

- those involved in awareness-raising or advocacy campaigns in relation to marriage practices or gender issues;
- organisations and individuals working to prevent violence against women in Afghan families;
- those who are seeking to work in any form of social or economic development project in Afghanistan and need to know about Afghan family dynamics and how marriage is conducted in the Afghan context; and
- readers seeking a deeper understanding of family dynamics and marriage in Afghanistan.

Key findings

The findings of this research are discussed in relation to six key areas of decision-making about marriage and marriage practices in Afghanistan:

- diversity in the processes used for making decisions about marriages and how marriages are practised;
- degrees of choice and force when decisions about marriages are made;
- the effect of compliance with cultural norms on marriages and marriage decisions;
- the divergence between personal desires and perceptions of cultural norms;
- the links between violence in the family and particular marriage practices; and

awareness within the community about the negative consequences of exclusionary decision-making processes and particular marriage practices.

Violence in the family and decision-making about marriage practices

The decision-making processes that lead to a marriage and the specific marriage practice undertaken can lay the ground for future violence between the couple and within the wider family. For instance, the research found that boys and men who are forced into marriage may take out their frustration at the situation by acting violently toward their wives or by taking second wives.

Diversity in how marriage decisions are made

A great deal of diversity was found among the ways in which decisions are made about marriages from family to family as well as from sibling to sibling within individual families. Many factors, both internal and external to the immediate family, affect how a decision is made and its outcome, including: gender and generational dynamics

within the family and the wider community; the experiences and characteristics of individual family members; the structure of a family or household at the time a decision is being made; and the prevailing economic and political situation. The degree of women's influence over decisions about marriages in their families changes over the course of their lives, depending on their relative status and the household structure. It was found, for instance, that elder, widowed women can have significant influence on decisions about marriages in their families. Individuals from similar demographic backgrounds can have quite different perspectives on the appropriate ways to decide about and conduct marriages.

Ways forward

Gross generalisations based on overarching demographic characteristics such as residential location (rural or urban), education or poverty levels cannot be made about what leads to particular decisions about marriages in families: the factors are too diverse.

Where marriage practices are involved, it is essential that reports, policies and programming disaggregate women and that the individual woman's status in the family is recognised. It is important to deconstruct stereotypes of Afghan women, such as that of the poor, vulnerable widow, and it should be recognised that Afghan men are also a highly heterogeneous group.

Choice and force in marriage decisions

The notions of choice and force figured prominently in the analysis of the data in relation to marriage decisions and practices. This report argues that conceptualising marriages as "forced" or "not forced" is an oversimplification of the way in which many marriages are decided upon. Instead, it is proposed that the way people enter into marriages operates along a range from choice to force. While some marriages may fall at one or other of the extreme ends of this range, many others feature elements of both choice *and* force.

An individual's age is a critical determining factor in their ability to give free and informed consent to a marriage, and it is at least as important to consider at what age a marriage is agreed to – or an engagement made – as it is to focus on the actual age at the time of marriage.

It is important to recognise that it is not only girls who are forced into marriages; so too are boys and older men and women. Similarly, not only do women suffer due to prevailing gender norms and the dictates these place on how marriages are decided on and practised; so too do men. Men who are compelled to marry at an age or time they do not choose or to a person they do not want can also end up in bad marriages, depressed and frustrated. This is not to negate the suffering of their wives, who may also be the victim of their husband's violence under these circumstances.

Ways forward

It is strongly recommended that organisations working to prevent violence against women in the family, in all its many forms, should work at least as closely with men as they do with women.

Equal attention should be drawn to the ages of children when their marriages are decided as it is to the ages at which they are actually married.

Cultural norms versus individual desires and opinions

Compliance with cultural norms and expectations leads people to enter marriages that they know may well present difficulties for them in the future. However, cultural norms and expectations for gendered behaviour are not rigid and do not go unquestioned, and this report demonstrates how frequently individual opinions and desires run counter to prevailing cultural norms and practices. The personal opinions of individuals – both women and men – were often more constructive, egalitarian and forward-looking than the cultural norms and practices of the communities in which they live. This divergence between cultural norms and personal desires shows that the practices adopted by individuals and communities are open

to discussion and that there is a readiness for change, at least among some members of the communities.

Awareness of the detrimental consequences of some marriage decisions

The primary reason for the differences between cultural norms and personal desires is an awareness of the detrimental consequences of exclusionary decision-making processes and certain marriage practices. Most people in the communities where the research was conducted are aware of the detrimental consequences of marriage practices such as *badal* (exchange marriage), high bride price and polygamy. A significant proportion of people also recognise that many of their cultural practices – such as not including children, both boys and girls, in decisions about their marriages and certain manifestations of polygamy and bride price – are contrary to Islamic principles. However, it was found that while this awareness and an openness to discuss these issues exists, alternatives to dominant practices or ways of breaking with the paying and receiving of bride price are rarely suggested or acted on.

Ways forward

Awareness-raising campaigns should focus not on telling people what they already know but on offering alternative ways in which marriages can be decided on and practised – within the constraints faced by different families and individuals. Organisations working against detrimental marriage practices and violence in the family should engage with communities to find economically and practically acceptable ways of conducting marriages which reduce the risk of harm, both psychological and physical, to women and men.

As this quote from an older man living in urban Bamyān shows, change will only come from the communities themselves:

Some customs and traditions jeopardise society. Forced marriage is against Islamic law and should be abolished. The people themselves should preach against this unlawful custom.

The preaching of the Human Rights Commission and Karzai doesn't affect them, and it is not enough.

This research has found that people are open to discussing the issues surrounding how decisions about marriages are made and the detrimental consequences of certain marriage practices. Organisations focusing on this area should provide opportunities for men and women of different ages to discuss these issues, allowing communities to devise their own decision-making practices for marriage that are more in line with their personal opinions and desires. This would provide alternatives to the cultural norms and social expectations that have led many to feel compelled to enter into marriages that they know will be problematic in the future.

There is some evidence of constructive changes already occurring in the communities where the research was conducted, as a result of the relative political stability they have experienced in recent years. As is the case with so many aspects of life in Afghanistan, perhaps the key to these changes continuing to take place will be the improvement of both political and economic security – allowing communities the space to begin to modify their marriage practices for the safety and wellbeing of families in the future.

Part 1: Theoretical, Methodological and Research Site Context

1. Introduction

In 2006 the Afghanistan Research and Evaluation Unit (AREU), with funding from the European Commission, launched a broad research project to investigate the changing nature of family dynamics in Afghanistan, particularly focusing on how family structure, gender, and generational roles and relations impact upon violence within the family. An understanding of gender and generational dynamics within the family is not only fundamental to explaining violence within the family, it is also important for the design and implementation of policies and programmes in a wide range of areas, including governance, health, livelihoods, and education.

This research project is concerned with the causes of violence in the family on three levels. First, it considers the root causes of violence, which include unequal power relations between men and women and constructions of masculinity and femininity in a given society. Second, it looks at triggers for particular acts of violence, which might include events or actions that create feelings of stress and frustration on the part of the perpetrator. Third, it examines practices or cultural norms within a given society which exacerbate violence in the family. While these different aspects of the causes of violence are closely related, their separation into distinct categories is useful for analytical purposes.

This report, which discusses marriage practices and marriage decision-making processes, is primarily concerned with the third cause: the cultural norms and practices which exacerbate violence in the family. It also references the first point, root causes of violence, and the second point, triggers for particular acts of violence. Looking at how decisions about marriages are made is revealing in terms of generational and gender relations within the family more broadly.

The institution of marriage is central to Afghan social life regardless of region, ethnicity or *qawm*. It is the central mechanism for both procreation and social reproduction. Family honour – and consequently family status – is maintained through the institution of marriage, with its role in controlling women's and men's sexuality. While the marriage "contract is formally understood as between bride and groom... clearly many other people, men and women, are involved in bringing it about and interested in the consequences."¹ Marriage is an agreement based on negotiation between two families or, in the examples of marriage among relatives, members of the same family. As this report illustrates, marriage decisions and practices are not only the result of desires and ideals but are also dependent on economic and social needs and strategies.

The family is often thought to be a private domain, however this perception arises from the false dichotomy of public and private life. In reality, not only is family life intricately intertwined with the community dynamics that play out in public spaces but it is also rarely free of state regulation. Marriage is one area of family life which states aim to regulate and legislate for; however, the extent to which that regulation actually affects marriages in the Afghan context is limited. In the context of a weak state at times counterposed by strong cultural practices at the local level, state regulation will, at best, have only a nominal impact on how people construct their families – beyond, perhaps, some members of urban communities. Recent research on community-based dispute resolution conducted by AREU found that disputes surrounding marriage negotiations and practices are frequently resolved through community-based institutions. This is not to say that state regulation is not an important, perhaps essential, component of the fight against

¹ Nancy Tapper, *Bartered Brides: Politics, Gender and Marriage in an Afghan Tribal Society* (Cambridge: Cambridge University Press, 1991).

harmful marriage practices. Gender-aware legal reforms can be both barometers of and precursors to broader social change.² It should also be remembered that while the reach of the state in Afghanistan is weak, Islam in the Afghan context serves as a fundamental link between how people conduct their lives and what the law regulates.³

Structure of the report

This report focuses on the perspectives, opinions and experiences of members of the eight residential communities where the study was conducted. Each section uses family case studies and shorter examples to illustrate the processes employed when deciding upon a marriage or to examine the marriage practices in use.

Part 1 comprises this introductory section along with Sections 2 and 3. It explains the context for the research, describes the areas where the data was collected and discusses the methodology. Some knowledge of the research methodology is essential to understanding both the findings and why certain data, such as statistical information, is not available.

Part 2 of the report, encompassing Sections 4, 5 and 6, looks at the decision-making processes leading up to a marriage. Using examples, this part of the report illustrates the considerable degree of diversity in how decisions about marriages are made. It also highlights the fact that individuals do not always influence decisions through overt, easily observable processes but sometimes in more subtle ways.

Section 4 focuses on the ways in which family members who are not those whose marriages are being decided on influence the decision. It

² For example, in March 2007 the Supreme Court of Afghanistan approved a new formal marriage contract which was hailed by women's rights organisations such as Medica Mondiale as a strong legal instrument to "empower women's legal status after marriage" (IRIN humanitarian news and analysis, 14 March 2007, <http://www.irinnews.org/report.aspx?reportid=70684>).

³ This is evidence by the shared Islamic ideals that are found both in law and among the community in Afghanistan.

illustrates how not only do gender and generation determine the role and authority an individual has in making a decision about a marriage but so too does household structure and a family member's individual characteristics. For example, some women are excluded from decisions because of their gender, while others are included or are primary decision-makers because of their position as mothers or grandmothers, their independent status or their role in the family because of particular household structures.

Section 5 discusses the roles and influence that children who are being married have in the decision-making processes about their own marriages. It explores the idea of forced marriage and shows that most decisions about marriage contain aspects of both choice and force: marriage decisions exist across a range from choice to force. Furthermore, it is not only girls but also boys who are forced into marriage, and this can have detrimental consequences for both spouses and the wider family. The discussion in this section highlights the differences between individual desires and personal opinions, and perceived cultural norms. It gives examples to demonstrate how individuals from similar backgrounds can have very different perspectives on what the current norms of behaviour are within their communities. While all cultures are in a constant state of flux, this section argues that the differences between personal opinions and cultural norms found in the communities where the research was conducted indicate that there is the potential and desire to move away from detrimental and exclusionary decision-making processes for marriage.

Section 6 is concerned with why people conduct marriages in ways they understand to be less than ideal, such as marrying their children when they are too young, not putting enough forethought into a decision and not consulting with their children about a prospective marriage partner. It identifies fear as a major factor in these actions: fear of what will happen to girls and boys during times of war and insecurity if they are not married; fear that another suitable proposal will not come; or fear that the parents will die before they see their children married or see their grandchildren.

Part 3 of the paper describes some of the commonly used marriage practices in Afghanistan, including exchange marriage (*badal*), bride price and polygamy. Section 7 argues that although both exchange marriage and bride price are dominant marriage practices, they are widely recognised by people – men and women, young and old, illiterate and literate – to be detrimental practices. Exchange marriage in particular was repeatedly criticised by respondents to the research, who recognised that it frequently perpetuates a cycle of violence and abuse directed toward the two women who have been married in exchange for one another. Bride price, as is commonly practised, was also identified as making women vulnerable to abuse in their marital homes.

Section 8 discusses polygamy and demonstrates that many people view a man having more than one wife as problematic. Examples are provided that show how both men and women feel compelled by social norms and expected behaviours to enter into polygamous marriages, knowing that these will be detrimental to both them and other members of the family.

Understanding the household

For change to take place in how marriages are conducted, there must be broad transformation in gender relations and norms in a given society, which requires fundamental changes across many institutions. Women's legal status in marriage is one such overarching concern; however, "arguably the most complex and elusive transformation may be in the relations within the family and household".⁴ Consequently, a broader understanding of family dynamics is essential to understanding marriage negotiations and practices – and where potential for changing them may lie.

Most of the literature concerned with gender dynamics in this context uses the household as the unit of analysis. A household has been described as a

group of people who co-reside for certain purposes that may include consumption, reproduction, socialisation, production and investment.⁵ The family, however, is based on relationships of biology, adoption and marital ties, meaning that the family may be a far bigger unit for analysis than the household. This research, with its focus on the family, is therefore concerned with relations among family members who may live in different households, compounds, villages or even provinces: family members who do not live in the same household may have influence over each other's lives. This is not to say that household structures are not important factors in an analysis which incorporates the wider family. Although all household structures change over time, households in Afghanistan have been particularly unstable, with constant migration – internal and external – both to escape war and to find employment. For instance, there are examples in Section 8 of men having married their sisters-in-law who were widowed due to war, and examples in Section 6 show war and migration encouraging younger marriages than would have been likely under different circumstances.

Understandings of household dynamics can also be used when researching the family and have provided an important conceptual background for understanding the data collected for this research. An early approach to understanding household dynamics, at least in western academic literature, was the unitary approach or "new household economics" approach, initially conceptualised by Becker⁶. This approach treats the household as if it were an entirely cooperative unit whereby "individual self interests combine seamlessly into family self-interest".⁷ This combining of individual interests, tastes, preferences and desires is seen

5 S. Chant, *Women and Survival in Mexican Cities: Perspectives on Gender, Labour and Low Income Households* (Manchester: Manchester University Press, 1991); B. Agarwal, "Bargaining and Gender Relations: Within and Beyond the Household," *Feminist Economics* 3, no. 1 (1997): 1-51.

6 G.S. Becker, *A Treatise on the Family*, Cambridge, MA: Harvard University Press, 1981, and "Human Capital, Effort and the Sexual Division of Labour," *Journal of Labour Economics*, 3 (1985): S33-58.

7 J.P. Jacobsen, *The Economics of Gender* (Oxford: Blackwell, 1994), 16.

4 G. Sen, A. Germain and L.C. Chen (Eds), *Population Policies Reconsidered: Health, Empowerment, and Rights* (Boston: Harvard University [Harvard Centre for Population and Development Studies], 1994).

to maximise the joint utility of all family members and, in doing so, enhance their overall wellbeing. This approach describes the combining of individual interests into a family interest as being achieved under the dictate of an altruistic household head – a benevolent dictator – who, it is implied, would be male. Moghadam points to similarities between this unitary model of household or family relations and those found in Islamic teaching: “A woman fulfils her functions by being a wife and mother, while a man is to be the undisputed authority, the breadwinner, and the active member in public life.”⁸

Some respondents saw the notion of a benevolent dictator as the ideal role for the male head of household within a harmonious family unit whose needs, wants and preferences could be combined:

I treat my sons the same. I mean when I buy for one of them, I buy the same for all of them. And we all eat together. Their wives don't have any authority to say do this or buy that, because it is my authority and I decide on everything. My sons remain quiet and don't say anything because they know I am here.

– Older man, Kabul city⁹

If there is a leader in the house, there are no arguments or fights. If there is no leader, the house will collapse. And in the leader's eyes everyone should be equal.

– Older man, rural Herat

The unitary model has been widely criticised by scholars concerned with gender relations and inequity within the family. They have “discredited the idea that households are unitary entities operating on altruistic principles and replaced this with the notion that they are arenas of competing

8 Chueiri cited in V. Moghadam, “Patriarchy in Transition: Women and the Changing Family in the Middle East,” *Journal of Comparative Family Studies* 35, no. 2 (2004): 137-162, 139.

9 In this report the term “older” to describe a respondent means they are in their mid 40s or above and most likely have grown children and grandchildren. The term “middle-aged” describes people between the ages of around 30 and 45 years, who may have grown-up, married children (some of whom may be married). Anyone below this age is described as “young”. Often respondents were not sure of their exact ages, which is one of the reasons these more generalised categories are used.

claims, rights, power, interests and resources”.¹⁰ The unitary model of the household, while for some may be an ideal prescript for family relations, is not in any context an accurate description of how families actually function.¹¹

Alternative conceptions of the household have been formulated which recognise conflicts of interests within the family and the reality that both gender and age determine differing access to resources.^{12,13} Most of these alternative paradigms of the household fit broadly within a “bargaining” model of household relations. One of the most comprehensive of these is Sen’s model of “cooperative conflicts”. In this understanding of household dynamics, household members are recognised as neither living in complete cooperation with one another nor in a perpetual state of conflict; instead, relationships among household members are made up of different degrees of cooperation and conflict.¹⁴ While often

10 S. Chant, *New Contributions to the Analysis of Poverty: Methodological and Conceptual Challenges to Understanding Poverty from a Gender Perspective* (Santiago: United Nations [Women and Development Unit, CEPAL], 2003), 19.

11 Despite its many inaccuracies and misconceptions, the unitary model is still used widely by policymakers. This may be because poverty levels are easier to measure when the household is left as a unitary whole, rather than taking into account differentials of poverty among household members (Chant, *New Contributions to the Analysis of Poverty*).

12 “Resources” are taken to mean more than simply access to material resources such as food, clothing and health care; the term also refers to less tangible resources such as time, information and freedom from physical and emotional pain.

13 For example: N. Folbre, “The Black Four of Hearts: Towards a New Paradigm of Household Economics,” in *A Home Divided: Women and Income in the Third World*, edited by J. Bruce and N. Dwyer (Stanford, CA: Stanford University Press, 1988) and *Who Pays for the Kids? Gender and the Structures of Constraint* (London and New York: Routledge, 1994); N. Kabeer, *Reversed Realities: Gender Hierarchies in Development Thought* (London and New York: Verso, 1994); H.L. Moore, *Feminism and Anthropology* (Cambridge: Polity Press, 1988); and A. Sen, “Gender and Cooperative Conflicts,” in *Persistent Inequalities: Women and World Development*, edited by I. Tinker (New York: Oxford University Press, 1990).

14 It is beyond the scope of this report to discuss in more detail Sen’s (1990) model of cooperative conflicts, which describes household members as bargaining over resources and explains how gender roles and relations affect their bargaining position. In particular, three ways in which gender roles and relations affect an individual’s bargaining position are highlighted: first, a person’s fall-back position and their vulnerability if the household unit breaks down; second, a person’s perceived interest, which may not always relate to their own well-

drawing attention to conflict within families and between spousal couples, this report recognises that cooperation between the genders and generations exists alongside conflict in a family. Section 4, for example, illustrates how families may be in conflict over certain aspects of marriage decisions while at the same time cooperating on other issues.

being; and third, their perceived contribution to the household, which may not relate to their actual contribution.

2. Methodology

Data for this study was collected in one urban and one rural location for each of four provinces: Bamyan, Kabul, Herat and Nangarhar. Research teams comprising two men and two women covered each province. In-depth, semi-structured interviews were conducted with over 200 men and women from 61 families. Many of the respondents were interviewed more than once. In total, 319 semi-structured interviews were conducted with different members of the 61 families. Fifty-six focus group discussions were also held, 28 with men and 28 with women. At the beginning of the fieldwork period, 46 key informant interviews were also conducted across the four provinces. Alongside these activities, ongoing informal conversations were held with members of the case study families and other community members. All interviews and focus group discussions were recorded using written notes which were then written up and translated as closely as possible into verbatim transcripts of what was said by both interviewer and interviewee. Field notes were kept to record pertinent informal conversations as well as the field researchers' observations.

Issues of translation were significant throughout the research process, with translations of particular words and phrases discussed at length by the English-speaking lead researcher and the Dari- and Pashto-speaking researchers. The research team endeavoured not only to produce a direct, word-for-word translation but also to understand the implications of certain word usages in Dari, Pashto and Hazaraji when translated to English.

2.1 Building the relationship between researcher and respondent

Researching the relationships between family members involves entering worlds that are commonly conceptualised as private and beyond the realm of public scrutiny. Talking outside (and often inside) the family about kin relationships can be perceived as disloyal, dishonourable and, at times, unnecessary or even futile. Consequently,

conducting in-depth research into family dynamics and family violence presents some particular methodological challenges. The key to overcoming these challenges is a research methodology which prioritises trust-building, flexibility and responsiveness to the dynamics of the field and the data as it is collected. It should also be remembered that researching family dynamics and violence in the family can be a distressing experience for those conducting the research. This is particularly the case when building a relationship based on trust between researchers and researched, which is essential to the collection of in-depth qualitative data.

In building trust and rapport, the most important factors were time and how the field researchers were perceived by respondents. There can never be enough fieldwork time for conducting a study of this nature; however, having different teams working in each province allowed for each team to work in two research sites over the course of seven months. While having many researchers working on the same project has some disadvantages (discussed below), it would have taken a total fieldwork period of two years or more to have collected an equal amount of data using just one research team.

Rather than working in one site for three and a half months and then moving to the next site, the rural and urban locations in each province were studied simultaneously.¹⁵ This allowed the researchers to build a relationship with the communities and the families they were studying over a seven-month period rather than just three and a half months. There were also practical considerations for choosing to work in this manner. First, the researchers' skills improved with time and it was important that they were working in both sites when their skills were the most developed – at the end of the seven-month period. Second, as the research teams gained new insights into the dynamics of the families, they were able to be responsive to this simultaneously across

¹⁵ In practice, this meant the research teams in each province spent two to three days per week in each research site.

both sites. Third, if there were security concerns or other unavoidable events in one site, they could continue to work in the other location, helping to prevent delays in the fieldwork process.

Perceptions of the researchers by the families they studied were fundamental to the researchers' ability to build trust and rapport. How the respondents perceived the researchers in relation to themselves influenced what they were prepared to reveal about their lives and the way in which they revealed it. When researching the private realm of the family, being seen as an outsider has distinct advantages and disadvantages. Likewise, there are also advantages and disadvantages to being seen as an insider. The research team for each province was selected with this in mind: each member was either from or living in the province where the research was being conducted, they were of the same ethnic mix as those being researched and, as far as possible, each team was made up of men and women of mixed ages and mixed marital statuses. In some ways, this allowed for the researchers to be perceived as the same as those they were interviewing. The researchers themselves also felt this sameness, making them able to empathise with those whose lives they were studying. Researchers at times shared their personal stories – experiences of war and migration, and conflict and cooperation within their own families. This mutual sharing of personal stories allowed respondents to feel understood and comfortable in sharing their own experiences.

However, in other ways it was important for the researchers to be seen as different or as outsiders. If researchers are seen as too closely linked to the communities in which they work, respondents can be less likely to talk openly for fear that they may judge them or share what they are revealing with other members of the community. It is sometimes those who live most closely with us whom we do not want to share our "private" stories with. One's status and standing in a community are dependent on what other community members know or think of that person; therefore, it is likely to be more important for respondents to paint a picture of harmony in their families to members of their own communities or those closely linked to their

own communities. In rural areas, the researchers were usually seen as "different" in terms of their urbanised, educated and formally employed status. In the urban context, these differences were less pronounced, however the educational and economic status of the researchers in relation to some of those being interviewed meant they were still seen as different on some levels. The women researchers were, on the whole, seen as different due to their employment status and greater mobility in comparison to many Afghan women. This was seen as an enviable position to be in by the women they were speaking to, rather than one to be criticised. Efforts were made to ensure that neither the researchers nor their families were known in the communities where the research was being conducted (this proved challenging in one province, with four researchers living in different parts of the city).

In relation to maintaining a degree of outsider status, the research teams did not seek introductions to the communities through NGOs that were already established in those areas. The first reason for this was that respondents may have thought that the information they shared would be passed on to NGO staff or that the research teams would become entangled in pre-existing power dynamics between NGOs and community members. Secondly, this avoided perceptions of researchers as being linked to an NGO which may provide some form of aid or assistance, and being seen in the same light. Outsiders are generally viewed as powerful in terms of being there to either give or take in some way. Early community meetings clearly demonstrated this: people either stressed their lack of material resources and asked directly for help, assuming that the outsider must be there to give, or they were reluctant to be interviewed and resistant to take part in the study, assuming that the outsider must be there to take in some way. Often, hospitality on the part of the community worked positively against these two reactions and gave the research teams time to explain the purpose of their work. To a degree, the research teams were there to take – in terms of information and time; however, it could also be said that the research teams gave back, with some respondents commenting on the fact that they enjoyed the opportunity to reminisce and talk about their lives.

In Bamyān, Herat and Nangarhar, the research teams were employed by the Afghanistan Independent Human Rights Commission (AIHRC), which collaborated with AREU in conducting the fieldwork for this study. Perceptions of the AIHRC and its work influenced how the researchers were received and what their role in the village was perceived to be. The AIHRC was well known in most research sites.¹⁶ The way in which the AIHRC was viewed by the communities varied: some saw it as protecting women from violence in their families and bringing positive change to the ways in which family members relate to each other. Others believed it to be disruptive to the family and thought it encouraged women to divorce their husbands. At times, this negative perception of the AIHRC made members of the communities where the teams were working reluctant to talk with the researchers about the relationships in their families and particularly about violence within the family. In a number of sites the researchers had to invest a great deal of time in explaining the motivations for their work to the communities. They emphasised that anything told to them would remain confidential and that no further action would be taken on the part of the research team. Where requested, the research teams had an ethical responsibility to refer people to organisations which could provide more practical support; if community members asked for direct help from the AIHRC, the researchers would tell them to contact the office directly.

As stated above, the data was collected using semi-structured interviews, focus group discussions, informal conversations and observations. The rationale for choosing these multiple, open-ended and flexible methods was to give respondents the opportunity to focus on what they saw as important in terms of gender and the generational dynamics within their families. Using these methods also lessened the potential for inappropriate anticipation by the research team of the full range of experiences being investigated.

In all sites, the research teams – both initially and after introductions with the community elders (both men and women) – engaged in many informal conversations with village residents and conducted key informant interviews with people who were knowledgeable about the communities. Key informant interviews were conducted with those who worked with the communities, such as healthcare workers and teachers, as well as those who lived in the community, such as the *malik* (community leader) or *daya* (traditional birth attendant). The aim of these interviews and informal conversations was to collect general information about the community – its history, politics and livelihood strategies – and to help identify case study families. Such conversations also proved to be a good way of building rapport and trust with key members of the community. Focus group discussions were used to elicit generalised information and opinions and perceptions about family dynamics and gender relations, including opinions on different marriage practices and individuals' rights in decision-making. The research teams used hand-drawn pictures of different scenes of family life, including aspects of violence, to encourage participants to discuss issues and topics of relevance to the study. As far as possible, members of the same family were not invited to be present at the same focus groups so that individuals would feel more comfortable sharing their opinions and feelings, although for practical reasons this was not always possible. Separate focus groups were held for men and women, and the teams further divided the groups according to their age and position in the family, taking into consideration individual status and influence in the community. Older men and women, usually with adult married children, were spoken to in one group, while younger men and women participated in separate groups. In some groups, some participants were married and some were not. A small number of discussions were held with groups of mainly unmarried or recently married men and women.

In each research site, case study families were selected to fit certain criteria. Five families who had a reputation for being violent and five who had a reputation for being harmonious were chosen in each

¹⁶ The researchers were employed by AIHRC to work specifically on this project and did not have any prior relationships with the communities as AIHRC workers. Similarly, the researchers did not seek introductions through other employees of AIHRC but introduced themselves and the project independently.

community.¹⁷ The researchers also aimed to select families living in different household structures and with varying economic and education backgrounds. However, while sampling is a relatively simple exercise, actually recruiting selected respondents in the field always proves far more problematic. The research teams were not able to identify and work continuously with the ten initially selected families in all sites. In several cases, as the research team got to know the selected families, it became apparent that two of the selected families were related; in these cases, these two families – including one in rural and one in urban Bamyan – came to be studied as one family.

2.2 Methodology used for analysis

Although the same methodology was used across all four provinces under study, some difficulty remains in conducting a comparative analysis based on each data set. Two interrelated factors contributed to this: first, the norms of social interaction in the different provinces affected how open respondents were in talking about their family members' lives; and second, the members of the research teams not only came with varying levels of skills and aptitude for qualitative data collection but were equally affected by their own social and personal characteristics. These two factors led to a wide range of opinions, emphases and stories coming out of the data, but these can no more be attributed to the different social, economic, demographic or political history of a particular province than they can be to the socially prescribed way of communicating about certain issues in the province or the behaviour, biases, skills and abilities of the research teams. Despite this, some significant variations were apparent between the provinces, and these are highlighted in the analysis of the data.

In order to be responsive to what arose during fieldwork, transcripts were continually reviewed and preliminary analyses of the data conducted. This allowed the research teams to identify areas

of insufficient data collection and to ensure that all the researchers were aware of new or unexpected themes emerging from the data. For instance, the intention at the start of the study had not been to produce a separate report on marriage practices, but this appeared as such a dominant theme throughout the research that it was seen to warrant its own report. Throughout the process, themes were identified, then later in the data analysis process these themes were coded. The data was then analysed horizontally across all the transcripts – that is, all of the transcripts of interviews and focus group discussions were examined as a whole, as well as province by province and research site by research site, to identify the common themes among them. Simultaneously, a vertical case study analysis of individual families was undertaken in order to keep the data contextualised and to gain an in-depth understanding of the dynamics within individual families. Family maps were drawn to represent both the structural relationships between individuals in the families as well as each household's location within the family structure (see Annex 1).

It is important to note that much of the analysis in this report is presented directly in the voices of respondents living in the eight communities where the research was conducted: it is clear that these men and women – literate and illiterate, wealthy and poor, old and young – have the ability to reflect on their own lives and understand the motivations for their actions.

¹⁷ Not all families who were reported by the communities to be particularly violent were; similarly, those reported to be harmonious were not always more so than others.

3. Research Sites

The four Afghan provinces where the research was conducted, Bamyan, Herat, Kabul and Nangarhar, were chosen in order to capture as broad a selection as was feasible of the different geographical and social contexts of Afghanistan. It is noted that research was not conducted in either the north or the south of Afghanistan; however, it would not have been possible to maintain the depth and quality of the data collected if a greater number of provinces were covered. Both rural and urban locations were selected to be as representative as possible of each of the four provinces and to capture the different experiences of war and migration typical of the resident populations. The presence of families from different wealth groups was also taken into consideration in identifying the study sites.¹⁸

Bamyan Province

Rural

Location and residents: The rural research site comprises five small villages with approximately 400 households in total, all within easy walking distance from each other. All residents are Hazara. The area is between one and two hours from Bamyan city by car, depending on road conditions (some roads can become impassable during winter). The area is particularly cold and experiences heavy snowfall in the winter months.

Livelihoods and economy: Of the rural areas where research was conducted in the four provinces, this is the poorest. Agriculture and animal husbandry are the main sources of livelihood. The majority of residents have no more than six *jerib*¹⁹ of land. Wheat, barley and potatoes are grown, predominantly for subsistence and animal fodder rather than for sale. Households also subsist on animal products such as yoghurt, butter, cream and milk, while selling animals and animal products

provides some cash income. People spend the spring and summer months living on their *ailaq* (areas of land outside of the village used for grazing animals) to access better grazing lands for animals. Families also spend this time collecting *bota* (bushes used for fuel) from the mountains for both cooking and heating during winter. Both men and women participate in animal husbandry. Carpet-weaving, undertaken primarily by women and children, is the most important source of cash income. According to interviews, however, it is not indigenous to the area – it was introduced by returning refugees from Pakistan.

For most households, everyday survival is a struggle. A village elder makes this clear in his description of economic variance among families:

The poor are those who have nothing to eat and the wealthy are those who have a few livestock and some land and can subsist on that.

Health and education: One school, built by an international NGO in 2002, serves all five villages, and classes are mixed for girls and boys. Residents value this school highly and have their children attend regularly. Even families who move to their *ailaq* during spring appoint an adult to stay with the children in the village and ensure that they go to school. Families are deeply concerned about the absence of medical services in the villages. The nearest clinic, which provides basic healthcare needs, is two hours away on foot. For more serious medical conditions it is necessary to travel to Bamyan city.

Impact of conflict: Taliban incursions into the rural areas of Bamyan Province were particularly devastating in this research site, with many men killed and imprisoned at the time. Families were forced to flee to the snow-covered mountains. Many old people and children died from the cold and lack of food, while many houses and possessions were either burnt or bulldozed. The village, located close to a shifting frontline between the Taliban and Northern Alliance forces, suffered not only at the hands of the Taliban but also when forces from

¹⁸ Research sites are described here to help contextualise the findings of the study; however, specific details about the areas have deliberately been omitted to protect the anonymity of the communities.

¹⁹ 1 *jerib* equals about one fifth of a hectare.

the other side were retreating. During the reign of the Taliban, very few of the residents were able to migrate to Kabul, Pakistan or Iran. A village elder reported that those who did leave the country are now better off economically than those who were internally displaced. He described the latter group as “just like a bird making a nest for itself”, alluding to their struggle to rebuild their homes, and their lives, from scratch.

Urban

Location and residents: There are approximately 500 households in the area. The residents originate from different districts of Bamyan Province, where they lived prior to being displaced by the Taliban, and, like the rural area studied, they all are Hazara. Upon returning to their villages after the fall of the Taliban in 2001, many families found their homes and livestock destroyed. This combined with other incentives for them to move to Bamyan city, primarily better access to services and employment.

Livelihoods and economy: Economic activities are more variable in the urban site than the rural area. Some wealthier families own trucks or cars used for transporting goods and people; others own small shops. For most people, however, income-earning opportunities are limited to daily wage labour and carpet-weaving. A number of families own land that they let for sharecropping; others are employed in the police force or work as guards.

Health and education: Bamyan central hospital and school are easily accessible to residents of this area.

Impact of conflict: Residents had had experiences of war and migration that were similar to those living in the rural research site.

Herat Province

Rural

Location and residents: The village is located 60 to 90 minutes drive from Herat city and is very close to the main road. All those living in the village are Tajik.

Livelihoods and economy: The rural area of Herat was the wealthiest of the sites visited. This was made clear to the research team in a key informant interview conducted with a female health committee member in the village:

We have a chopan [shepherd] we can call poor. But even he is not that poor, because we give him our sheep to take care of. And at the end of the year for every ten sheep he looks after we give him one, as his salary. So in every year he gets at least 30 sheep. And the people also give him his living expenses.

Agriculture and animal husbandry are the main sources of livelihood. Generally families own significant amounts of land, both irrigated and rainfed, and livestock. Most families have surplus produce which they sell along with animals and animal products. It is very common for young men from the area to work in Iran for periods of time in order to provide for their families and, more commonly, to raise money for marriage expenses.

Health and education: There is a small school to grade five in the village. The nearest school for older children is in the *waliswali* (central town in a district), approximately 20 kilometres away. Similarly, there is no health clinic in the village and the nearest health services are in the *waliswali*.

Impact of conflict: Residents of the area were affected both by the Soviet-mujahiddin war and the Taliban’s control of Herat Province. At the time of the Soviet occupation, the village was divided into two factions, with half the village supporting the Soviet-backed government and the other half supporting the mujahiddin. By the early 1980s, the conflict had forced all the families to leave the village. Some families fled to Iran, while the majority went to a neighbouring province; they returned after seven or eight years. Under the Taliban, some men were imprisoned, tortured or killed. Some joined the forces fighting the Taliban and left the village. However, families as a whole were not displaced from the village at this time.

Urban

Location and residents: The urban site covers a relatively large area and is located not far from the centre of Herat city. The majority of residents are Tajik, with the largest minority being Turkmen. There are a few Pashtun and Hazara families.

Livelihoods and economy: Overall, families in the urban site are poorer than those in the rural area, although there is a range of economic situations: some are materially comfortable, while others have no regular income at all. The wealthier households own shops or small businesses, and some also own productive land in the rural areas. The occupations of men from less economically secure families include: selling vegetables from a cart; daily wage labour; driving taxis; working as security guards and cleaners; and working for government institutions such as the Afghan National Army. Women's economic activity is important in this area. Women support their households by sewing *lehaf* (quilts), smashing pistachios and washing clothes for wealthier families. Carpet-weaving is also done, primarily by women from Turkmen families. Remittances from male family members working in Iran are an important part of economic survival for many families in this area.

Health and education: Residents have access to one health clinic in the area and two others nearby. There is no school within the study site, but there are schools for both boys and girls close to the area.

Impact of conflict: The area was severely affected by the Soviet-mujahiddin war. It was heavily bombed by the Soviet forces. Families interviewed had lost some family members, while others were severely injured or disabled. Residents were forced to flee at this time; some families moved from place to place in the city or to different districts of Herat. A significant number of families migrated to Iran, while many of the Turkmen families living in the area went to Turkmenistan. Most of those who left returned in the early 1990s, and many new families who were originally from other parts of Afghanistan also moved to the area. As was noted in the rural research site, migration to other countries during the Taliban regime was minimal; however, family

members were reported to have been imprisoned, beaten and executed by the Taliban.

Kabul Province

Rural

Location and residents: The rural location in Kabul Province is about 45 minutes drive from Kabul city, and the village comprises approximately 320 households. The majority of the residents described themselves as Arab²⁰ and speak both Dari and Pashto. There are a few Hazara families, but all those interviewed for this study are Arab.

Livelihoods and economy: Families are of various wealth levels, including large landowners and those with no land who are dependent on daily wage labour. Agricultural products, such as wheat, potatoes, onions and fruits, are used for subsistence and also sold in Kabul. Animal husbandry is practised, and its products, such as yoghurt, are also sold in Kabul city. Some families have shops or operate handcarts on a daily basis. A number of households own cars that they operate as taxis to and from Kabul. A small number of women participate in economic activities, including tailoring and selling animal products locally.

Health and education: The village has a school for boys and girls, with classes up to grade five. The nearest school for grade six and beyond is at least an hour away on foot. The closest health clinic is in the next village, approximately 30 minutes walking distance.

Impact of conflict: The village suffered greatly during both the Soviet-mujahiddin war and the subsequent civil war. Residents recalled that buildings and fruit-bearing trees were destroyed in the fighting. Many families lost male family members – mostly those fighting with the mujahiddin – during the wars. The civil war also affected the village, with local commanders fighting over land. The vast majority of families fled the village during

²⁰ Groups identifying themselves as Arab in Afghanistan are among those claiming Sayed descent (E. Yarshater [Ed], *Encyclopedia Iranica Volume 1* [New York: Biblioteca Persica Press, 2001], 499).

the Soviet-mujahiddin war — mainly to Pakistan, but some to Kabul and a small number to Iran. Many village residents went to the same refugee camp in Pakistan and reported that they were able to maintain their culture and social structure in exile. The village's residents returned at different times: prior to the outbreak of civil war some families who had returned were then forced to leave again. Most families, although not with all members in all cases, have now returned.

Urban

Location and residents: The site is typical of informal settlements in urban Kabul, which have sprawled up the side of nearby mountains. Unlike the rural Kabul site, people from different ethnicities live in the urban location, the majority being Hazara, Pashtun and Tajik. Many are either returnees from Pakistan or people who were internally displaced, while some are longer term residents of the area who moved to Kabul two to three generations ago.

Livelihoods and economy: There is a range of sources of livelihoods in this research site: some residents work as civil servants, others own shops, while many families rely on remittances from relatives working abroad. Some own land in other parts of the country from which they derive income. There is a high degree of under-employment and unemployment. Some women and children are involved in carpet-weaving.

Health and education: There are private health services along with one public health clinic in the area. There are two schools — one for boys and one for girls.

War and migration: The area was near the frontline during the civil war. Many buildings were destroyed, and most if not all residents left the area during the conflict.

Nangarhar Province

Rural

Location and residents: The rural research site in Nangarhar is a particularly large village. It takes

just over an hour by car to get to the village from Jalalabad city, including a 15- to 20-minute drive from the main road. The residents are all Pashtuns, but from different *qawm*. There is a bazaar with a number of different shops in the centre of the village.

Livelihoods and economy: Residents are from a range of wealth groups. The wealthiest own businesses and shops as well as land. Those in the lower income groups work as drivers or daily wage labourers, while others have small plots of land. Most of the people interviewed during this research own between 2 and 10 *jerib* of land. Wheat is the most important crop, while cotton, maize and vegetables are also grown. Some families also have livestock. A small number of women in the village are involved in paid work: one is a teacher, another is a midwife and two are trained birth attendants. Other women work as seamstresses. A few residents work in government and NGO offices. According to the villagers' accounts, the community used to be wealthier when opium poppy was grown; however, most villagers have reportedly stopped cultivation. As in other research sites, some male family members work in Iran or Pakistan as a form of household economic survival.

Health and education: The village has a functioning clinic with both male and female medical staff, including a very active and dedicated midwife. There is a boys' school and a girls' school in the village. However, residents complained that the girls' school only goes up to grade six and that it is difficult to recruit female teachers.

Impact of conflict: The Soviet-mujahiddin war left most of the buildings in the village destroyed. Many families lost members and most residents migrated to Pakistan, staying there for between 14 to 20 years. In some cases, families split up as a survival strategy, with some members staying in the village to look after their land and property.

Urban

Location and residents: The residents of the urban research site were originally from a number of different districts in Nangarhar as well as from

other provinces in Afghanistan. The majority are Pashtuns from different *qawm*, while there are a few Tajik families.

Livelihoods and economy: This is one of the poorer areas of Jalalabad city. There are, however, a small number of wealthier families. The men in the area earn their incomes as masons, daily wage labourers, porters, policemen, army soldiers, drivers, cart pushers and small shopkeepers. Some residents own small businesses as well as land for lease in the rural areas. Women's economic activities are minimal, but some undertake paid work, including sewing *brastan* (quilts), teaching or working in health centres. Overall there are high rates of under-employment and unemployment. As in most of the other research sites, families have male members living and working in Pakistan and Iran.

Health and education: There is no health clinic in the area and only one school for boys and girls up to grade six. However, being in the city there are other health facilities and schools nearby.

Impact of conflict: Many of the current residents first came to the area during the Soviet-mujahiddin war to escape the fighting in their home districts. Many families, however, were forced to flee again during this war, with some going to other districts of Nangarhar and others moving around the city itself to avoid the fighting. Some of the residents also migrated to Pakistan and stayed there for up to 20 years or more. The area was heavily bombarded and many households have members who died or became disabled. Residents also suffered during the civil war and the Taliban rule, and during the American bombing of Taliban positions, many were again temporarily displaced.

Part 2: Decision-Making Processes About Marriages

Marriage decisions are influenced by many factors both internal and external to the family. Factors internal to the family include the structure of the household and family, the gender and generational dynamics of the individual household and family and the individual characteristics and life histories of family members. External factors include gender and generational dynamics in a given community, the current political, economic and social situation and more specific issues such as the timing of a proposal. These all affect the decision-making process, who initiates it, when it is initiated and what form it takes.

There is great diversity in how decisions about marriages are made from family to family and within individual families. Those playing a role in decision-making include grandparents, parents, aunts, uncles, siblings and the children whose marriages are being decided on. The amount of influence over a decision that these individuals have within different families also varies considerably. Decision-making processes also change over time within individual families, and this change can happen over a short period of time, for example from one sibling to the next.

Decisions about marriages can be divided into two distinct types: first, decisions made about the marriages of those who have never been married; and second, decisions made about the marriages of those who have been married before – that is, people who have been widowed or divorced and men who are marrying a second, third or fourth wife. The following three parts in this section are concerned with decision-making regarding the marriages of those who have never been married before. Decision-making processes for those who have already been married are discussed in Part 3.

Three important aspects of a marriage are decided on prior to the marriage taking place:

who the marriage partner will be – often families are just as concerned about the family of the marriage

partner as they are about the characteristics of the prospective spouse;

the timing of both the engagement and the marriage – what age or stage in life an individual is when they are engaged and when they are to be married; and

how the marriage is to be conducted and under what conditions – if bride price is paid, how much will it be, and if the marriage is based on the exchanging of women (*bada*), whether both couples will be married at the same time.

Discussing only overt decision-making processes – such as people coming together to discuss an issue – does not provide the best assessment of the forms and levels of influence and authority that individuals may have. The sections that follow, therefore, discuss not only the positions of those who are easily observed or reported to be a decision-maker but also the ways in which those who have less overt access to decision-making processes are able to more covertly influence decision-making outcomes. Account is taken of the different ways in which decisions are influenced, including verbal support of or opposition to a decision and more subtle or indirect forms of showing resistance or acquiescence to a decision. In order to capture this information during data collection it was important to discuss with respondents *how* a decision was made rather than simply asking *who* made the decision as well as asking how an individual felt about a particular decision and how they were able to share their feelings with the rest of the family.

At the heart of any decision-making process is the notion of choice: the options or choices individuals and groups have before them when making decisions. Kabeer makes a distinction between first- and second-order choices.²¹ First-order choices are the strategic life choices people

21 N. Kabeer, "Resources Agency and Achievements: Reflections on the Measurement of Women's Empowerment," *Development and Change*, 30 (1999): 435-464.

make, such as livelihood decisions and when and who to marry, while second-order choices may be important but do not define the parameters of a person's life. Both of these sets of choices can be constrained on many levels. Early work by Lukes in theorising about power drew attention to the way in which choices are restricted by what comes to the decision-making agenda.²² It is argued that control of what is "decisionable" is maintained through the creation and reinforcement of certain social norms and that control of what comes to the decision-making agenda operates on two levels. First, options are limited on an unconscious level, with certain things not even being thought of as a choice. For example, for most Afghan families the question of whether to get their daughters or sons married at all would not be seen as a decision to be made, as not marrying a child is not seen as an option. Second, even where different options beyond the norm may be imaginable, the consequences for individuals and families of non-compliance with prevailing social norms may be too detrimental to be perceived as a real choice.²³

The importance of an in-depth examination of the decision-making processes leading to a marriage is demonstrated by the stories that respondents relayed to the research team about how "mistakes" made during the decision-making process have led to violence toward the woman who is married as well as feelings of remorse and regret on the part of those who were dominant in making the decisions. This part of the report argues that the way in which a decision is made – who is included and who is excluded, and whose opinions are listened to and whose are ignored – may act as a determining factor for future violence between the couple and in the wider family.

22 S. Lukes, *Power: A Radical View* (London: Macmillan, 1974).

23 It should be noted that Lukes' work has been criticised by others (such as Kabeer, *Reversed Realities*, and M. Haugaard, *Power: A Reader* [New York: Manchester University Press, 2002]) for relying on the notion of false consciousness to explain the continuation of the subordination of particular groups in society, as it implies that groups are not aware of their own interests.

4. Gender, Generation and Status: Roles of Men and Women in Marriage Decisions

Household structure and gender and generational dynamics within a family interact to determine the level and form of influence that individuals have in decision-making processes regarding marriages. While social rules apply and provide an overall context in which families operate, the way in which they function is complex and adaptable to different circumstances. A broad range of family dynamics and household structures were found across the eight different research sites, and significant variance in the level and form of different family members' participation in and influence on decision-making about marriages was found. Similarly, there were varying degrees of cooperation and conflict around these decisions.

The role and influence that women have in decision-making processes within the family tend to be more complicated and variable, and therefore harder to observe, than that of men. Men often have a more overt role in the process, while women have to use more covert methods to influence decisions.

4.1 Factors encouraging women's influence in marriage decisions

In buying things and building the house, they [men] don't ask us and they don't listen to our ideas and wishes, but for children's marriages a mother has the right to give her opinion.

— Middle-aged woman with 5 young children, Herat city

Yes, they [women] participate in decision-making and they should participate so that there won't be any conflict in the home.

— Man in his mid 50s with 8 children, rural Bamyan

Many people in the eight research sites — both men and women, and those of different ages — were found to believe that women in the family should play a role in the decision-making process about their children's marriages. However, this does not mean that all women are in a position to

substantially influence decisions about marriages. Some women are able to play a role, while others are excluded.

The degree of influence that a woman has changes throughout her own and the wider family's life course. A woman who may have found it difficult to influence decisions at an earlier stage in her life usually gains more authority as she becomes older, particularly if she is widowed and perhaps also the oldest person in the family. In this case she may even become the primary decision-maker regarding the marriages of her children and grandchildren. It was reported by several men interviewed that their mother or *nasaka* mother (father's wife but not biological mother) had made the decision about their marriage. For example, Nader Shah,²⁴ a man in his mid 50s from rural Nangarhar explained how his *nasaka* mother had made the decision about his marriage as "she was old and wise" and his father had died.

Under other family circumstances and household structures, women who are younger can also be influential. For instance, Bas Bibi, a woman who is now in her early 40s, was married into a relatively wealthy and educated family in Kabul city (family map 1). At the time of her marriage there were no other married women living in her marital household. While she told of her father-in-law taking ultimate responsibility for who his children would marry, he relied on Bas Bibi to visit the families of potential spouses and discuss with the women of these families the possibility of the engagement. This process gave her considerable ability to shape the outcome of the decision-making process. A very different example of a younger woman playing a significant role in marriage decisions is that of Latifa (family map 2). Latifa is a widow in her mid 30s with young children who has not married again after the death of her second husband. Although she is very poor, she lives in her own home close to her parents in Bamyan city. Despite having adult

²⁴ All names in both the text of this report and in the family maps have been changed to protect respondents' identities.

brothers and her parents being alive, she played a key role in the negotiations for the marriage of her cousin, who lives with her natal family. Latifa's position as a woman living independently but close to and with the support of her natal family is most likely the reason that she was relied on to give support and advice in arranging this marriage.

Women's influence in decision-making can increase over the course of a family's life cycle as the men in the family come to rely on the advice of their wives. For instance, several cases were found of men having made decisions about their daughters' marriages which they later regretted. In response to this, they had either handed the entire responsibility of decision-making about marriage to their wives or had become more inclusive in how they made such decisions. Nowrooz Bay (family map 3), who lives in urban Herat, refuses to be involved in decisions about the marriages of his children since he married his elder daughter to a man with severe psychological problems. He had agreed to the marriage without meeting the boy or, according to his wife, getting to know the boy's family well enough. As his wife, Masooda, explained, the rest of the family blame Nowrooz Bay for the difficult circumstance his daughter is now in. He has since relinquished his responsibility for decision-making about the children's marriages to his wife, as she explains:

Yes, I will decide. For my daughter's marriage to this crazy man my husband introduced this family to us and he felt positively about it. We then blamed him. After that marriage my husband left everything about my daughters' marriages to me... [My son's marriage] is also in my hands.

Nowrooz Bay's complete relinquishing of power over decision-making about marriages may be his way of ensuring that he does not have to take the blame for any future badly made decisions about his children's marriages, and it could be argued that he is handing a burden of responsibility to his wife. However, the way in which Masooda explained to the research team that these decisions are now her responsibility indicates that while it may be a burden, it is one she is happy to take on.

A similar example comes from Shamsia's family (family map 4). They are a poor family living in urban Nangarhar, surviving on Shamsia's father's income when he is employed (at the time of the research he had some work as a watchman) and Shamsia's own small but more regular earnings from running a literacy class for girls. Shamsia's elder sister was married during the Taliban regime: the groom's family had proposed and in consultation with Shamsia's paternal grandparents her father had agreed to the marriage. While her father says that because it was during the time of the Taliban it was very difficult for him to refuse the proposal, Shamsia explains that her father is very regretful about marrying his elder daughter in this way:

It was my grandfather and my father who engaged my sister without letting her know about it.... Yes, they had spoken to my mother; my mother said she didn't like that family and she didn't want to marry her daughter with them, but my father said the man's family insisted and so without taking into account my mother's and sister's views, my father decided to engage my sister and marry her... My father has now learnt from his mistake and he'll definitely ask everyone about any decisions [in the future].

This change in opinion is something Shamsia's father confirmed, linking the change in decision-making processes in his own family to the change in government in Afghanistan:

I will never interfere in [my children's] marriages again and I will let them marry according to their own wishes... This is a time of democracy so everyone is free to marry who they want to.

While in these examples the situation was described to the research team as if the power over decision-making in the family had been handed to women, in other cases women describe themselves as taking this power for themselves. Fauzia (family map 5), who is in her 40s and illiterate, is adamant that she and her daughter will have the ultimate say in who her daughter marries:

I will marry my daughter with the man that she wants to marry. If anyone comes here for

khoostgari [proposal for marriage], I will ask my daughter which one she wants to marry... I will tell my husband that I have only one daughter. I have full authority over her and I will get her married.

Fauzia's determination is related to a bad decision her husband made, against Fauzia's advice, in marrying one of Fauzia's *nasaka* daughters (daughter of one of her co-wives) to a man the family had never met.

Suraya (family map 6), an older illiterate woman from a poor household in urban Herat, explained during her first interview why it is her alone who will decide on her children's marriages:

I decided to give my daughter to them and I didn't give any rights to my husband. He is not a father to them. What is he doing for them so that he can ask about their marriages?

During her second interview, Suraya was more charitable toward her husband, admitting to him having some say in the children's marriages:

I got [my elder daughters] married by myself, but I was telling my husband and my brother-in-law about it and they were happy. My husband told me, "You marry them if you like".

These women who have taken on the decision-making power over their children's marriages are certainly in the minority and in quite unusual family situations. Fauzia, who is illiterate, lives separately from her husband and his two other wives and any other in-laws in rural Bamyān. She is Juma Ali's second wife and has only one surviving daughter from the five children she has had. She separated herself from her husband when he took a third wife, telling him that if he did not build her a separate home to live in, she would divorce him. Suraya, who is also illiterate, similarly does not live with any in-laws and has been particularly dominant over her husband since she stood up to his violence. Suraya had an unusual childhood: until she reached puberty and was married, she was brought up as a boy – perhaps influencing her ability to resist her husband's violence. Her husband is over 20 years older than her and now quite frail, a further contributing factor to her ability to take

control of the decision-making about her children's marriages. He is a cart-pusher who, according to Suraya, is unable to provide for the basic needs of the family – part of the reason she sees him as not being an adequate father to their children.

Even in cases where a male head of household is viewed as the ultimate decision-maker, the process undertaken to make a decision about a marriage can provide women with the opportunity to influence the final outcome. The most significant way in which they may be able to do this, at least for marriages that are not to a relative already known to the family, is through the role they play in visiting the families of prospective spouses, as described here by an older man from Bamyān:

Yes, [the women] tell me that so-and-so is a good girl, she has good behaviour, she knows how to do the housework and her parents and family are good. Yes, they participate in decision-making.

As discussed in the methodology section, it is difficult to draw conclusions on many issues based on comparisons between the different provinces where the research was conducted. Nevertheless, while women across all the provinces play some role in scrutinising prospective spouses' families, it appears that women in Bamyān play a greater role in this than in the other provinces. This is likely to be related to the higher degree of mobility that Hazara women have, due to less rigid norms of sex segregation and women's seclusion in these communities than in those of other parts of Afghanistan.

Women are sometimes able to find more covert means of influencing the outcomes of the decision-making process. While these may be harder to observe and report on without actually living with a family for an extended period of time, through careful examination of interview transcripts it is possible to see the ways in which this may operate. An example of this is the role Atika plays in determining the outcomes of decision-making regarding her eldest son's marriage. Atika lives in rural Bamyān with her husband, Haleem, and their five children, all under the age of 20 (family map

7). Against the wishes of his wife, Haleem had engaged their eldest son to his sister's daughter. The engagement has now been broken. It is possible to see from what Haleem says about the breakdown of this engagement that his wife, Atika, intervened to prevent the marriage from happening:

Both sides [decided to break the engagement]. My wife had said to my sister that my son did not want to marry her daughter, then my sister said to my wife that her daughter was not willing to marry either... [My wife said it first], because my son said he would not accept the girl.

Haleem may see himself as the primary decision-maker in the family; however, it is clear that his wife was able to resist the outcome of a decision which had not accorded with her wishes.

4.2 Factors limiting women's influence in marriage decisions

Individual family circumstances also serve to exclude some women from decisions about the marriages of children in the family. The dominance of older women in the decision-making process can be at the expense of the role of younger women – particularly the mothers of the children whose marriages are being decided on; for example, a mother-in-law's counsel may be taken instead of that of a mother. One example of this is Shereen (family map 8), who lives in urban Nangarhar and is now in her early 30s. Shereen's mother had objected to Shereen's marriage because she felt her daughter was too young to be married. Shereen's paternal grandmother overrode her opinion and insisted that the marriage take place. Shereen explained how it was difficult for her father, who was also not in support of the marriage, to go against the wishes of his own mother and support his wife, as Shereen's paternal grandmother had brought Shereen's father up alone, refusing to marry again. The distress that Shereen's mother and other women in similar positions feel at being excluded from decisions about their children's marriages provides further evidence that there is a certain level of expectation for mothers to be included in decisions about their own children's marriages.

Women who have particularly domineering or violent husbands were found to be more likely to be excluded from the decision-making process about children's marriages, which can happen because they are restricted from taking on the traditional role of women in these processes. For example, Zeba, who is the oldest woman (in her 60s) living in a relatively wealthy family in Bamyan City, was prevented by her very violent husband from socialising among the community (family map 9). Her son, Baser, explained how this meant she was not in a position to select potential spouses for her children as other women do.

Jamila, from urban Nangarhar, is another example of a woman whose exclusion from decision-making processes is related to the violence she experiences at the hands of her husband. She tells of how her husband got her young daughter engaged without consulting with her:

When we got our daughter engaged my husband didn't inform us. At that time she was just seven years old; six years later we married her. Sometimes when I say to my husband that we will engage our son in the future he agrees that we will do that, but I will find a very good girl for him who should be pretty. So when we make decisions, my husband is the decision-maker.

However, Jamila is not resigned to this situation:

Yes, [I want to be involved in the decision]. Why not? They are my children too. I want to make the decisions for them, but unfortunately my husband does it. He doesn't let me make decisions because he says, "Women are not clever, therefore I don't ask women about difficult things. Only I should make the decisions."

A minority of women who are excluded from decisions about their children's marriages explained it in terms of cultural norms. For example, two sisters-in-law (married to two brothers) who live in a large household in urban Nangarhar (family map 10) both reported that the men in the family make the decisions about marriages. They argued that this is the normal way things are done in their community:

Whether we agree or not, it is our custom, so we can't do anything. If we don't agree it is [men's] work, in time we have to accept it because we are Pashtun.

— Sarwaro, urban Nangarhar

One other thing I should tell you is that in fact my husband has the authority over his children. I don't have the power to make decisions because our men say that men should make the decisions, not women.

— Kamila, urban Nangarhar

It should be noted that both these women live in a particularly conservative family (described in more detail in the following sub-section).

The first two parts of this section have identified certain family circumstances that may enhance women's abilities to influence decisions about the marriages of the children in their families and others which may restrict that influence. First, it was identified that many people in the communities believe that women should have a say in marriage decisions for the simple reason that it makes for better decision-making. However, this is not universal: some women explained their exclusion from the process in terms of social norms. Second, as women become older and their relative status in the family is greater, the value placed on their decisions increases. This was found to be particularly the case for widowed women who are the eldest in the household. At the same time, the status accorded to older women can limit the participation of younger women in the family, particularly mothers who are living with their mothers-in-law. Third, younger women may have influence under specific family circumstances, such as when they are the only or eldest married woman in the family or when they are in a position that confers certain status upon them (such as Latifa). Fourth, women's influence in the family may increase over time as men relinquish some influence and power to them or as they assert their desire to be responsible for decision-making. Fifth, the role women play in visiting the families of prospective spouses is accepted (however, certain women living with particularly violent or domineering husbands were found to be restricted from taking on this

role). Finally, it should be remembered that even in circumstances where women appear to have no role in decision-making, it is possible for them to find ways in which to influence decisions through more covert means.

4.3 Factors affecting men's influence in marriage decisions

The degree of influence that men have in decision-making processes about children's marriages also varies from family to family. The overall greater degree of power that men have in Afghan society usually gives them more influence than women, but despite this not all Afghan men, any more than all Afghan women, have equal degrees of influence within their families. While fathers, grandfathers, uncles and brothers may all have substantial influence on decision-making processes, the different degrees of influence they have is determined by individual relationships between family members and the family's structure at the time a marriage is being decided on.

Sometimes fathers, like mothers, are excluded from decisions about their children's marriages or have less influence in the process than older men in the family. For instance, Saghar, who is in her 60s and lives in urban Kabul, reported that it was her parents-in-law who decided on her eldest daughter's marriage — excluding both her and her husband from the decision-making process. However, it was her and her husband who married their other three daughters. While the data does not reveal exactly how this change came about, it can be surmised that as Saghar and her husband became older and had more grown-up children, their status in the family was enhanced — allowing them to assert more authority during these decision-making processes.

Uncles, usually older uncles, can have considerable influence over the decisions about their nieces' and nephews' marriages. This is particularly the case where the grandparents are elderly or have died, leaving neither a woman nor a man of the older generation in the household. It was also found that even when brothers have separated their households, they can still have significant influence

over the decisions in each other's families. This is exemplified by Riaz's family in urban Nangarhar (family map 11), which, like many of the families in this part of Nangarhar, is very poor and at times struggles to have enough to eat.²⁵ One of Riaz's brothers lives in the same compound as Riaz, as do his two wives, their children and Riaz's mother. His other two brothers and their families live separately. Riaz reports that when it comes to marrying his children, it will be him with his brothers who decide; his wife confirms this. Similarly Zalmi, Riaz's younger brother, reports that if his brothers are present, they will decide, and only if they are not present will he and his wife and mother make the decision. It appears that women in this family can only have a say in the marriages of their children if their children's uncles are not present.

Another example of uncles having considerable influence over their nieces' and nephews' marriages comes from rural Nangarhar. However, in this case it is the younger of two brothers who live in separate households who has the greater influence (family map 12). Snawbar, the wife of the elder brother, explains how her husband's younger brother asserts his influence over decisions about the marriages of her children:

This decision is not up to [my husband]. My husband will agree with whatever Abdul Fataa, my brother-in-law, says. If my husband does not listen to the opinion of his brother, then Abdul Fataa will be upset with us, and this would not be acceptable.

It is difficult to know exactly why Abdul Fataa has so much influence — even in his older brother's family, but factors such as his higher level of education and greater economic status are likely to be important. It should be noted that Abdul Fataa made the decision about Snawbar's eldest son's marriage and that this is seen as a disastrous marriage by all the members of the family; however, unlike other cases discussed earlier, this has not led him to relinquish his decision-making power.²⁶

²⁵ Riaz's family is discussed in greater detail in Section 8 in relation to the dynamics between Riaz and his two wives.

²⁶ The consequences of this marriage decision are discussed in

It is not only uncles who can play a significant role in the decisions about their nieces' and nephews' marriages but also male siblings in relation to their brothers' and sisters' marriages. In some cases this may simply be through being consulted during the decision-making process, particularly where fathers have died and elder brothers have taken on a key decision-making role in the family (often alongside their widowed mothers). For some this may mean that brothers make decisions against their sister's wishes, as this young woman explains in relation to the decision about her brother-in-law's wife:

The girl herself wasn't happy, but her brothers wanted it to happen. As she is a girl, she had to accept it.

In other cases brothers can be advocates for their sister's well-being. Examples were found of brothers attempting to prevent the marriage of their sisters to men who they or their sister were not happy with. In one example from rural Nangarhar, a man reported that his father told him to leave the house because he was causing so many arguments in protest at the marriage his parents had arranged for his sister. In another example from rural Kabul, a brother's arguments with his father about the engagement of his sister led him and his sister's future brother-in-law to fight each other with knives. In both these cases the brother's protests went unheeded and their sisters were married to the men their parents had chosen for them.

4.4 Conclusion

This section has discussed the different roles that men and women in the family play in decision-making about children's marriages. It has demonstrated that there is a considerable amount of diversity between families and within families regarding how decisions about marriages are made. Not only do gender and generational dynamics affect women's influence relative to that of men but so to does household structure, individual family life histories and individual characteristics. Similarly, individual family circumstances can affect men's levels of participation in the decision-making process.

Sections 5 and 8.

While certain general similarities are found between families, such as uncles and brothers having influence over marriage decisions in relation to their nieces, nephews, brothers and sisters marriages as well as a general – if not universal – belief that women in the family should have say in arranging marriages, a great deal of complexity is found in the ways in which different family members are included in the decision-making process. Families can also undergo changes in their internal decision-making processes within short periods of time. These factors combine to demonstrate that while cultural norms and expectations for gendered behaviours certainly exist, they are not rigid; instead, they are modified and uniquely interpreted to fit in with different family circumstances.

5. Choice and Force – Role of Children in Marriage Decisions

This section examines the role and influence that children²⁷ have in decisions about their own marriages. In the first part the concept of forced marriage is discussed, and it is proposed that conceptualising marriages as either “forced” or “not forced” is over-simplifying the issue and has the potential to limit understandings of the many ways in which marriages are arranged. Instead, the degrees and forms of individuals’ influence over decisions about their own marriages is better understood as operating over a range from choice to force. The second half of the section argues that issues related to how much influence children should have over decisions about their own marriages are open for discussion within the communities where the research was conducted. This is demonstrated firstly by the divergence found among people’s personal opinions and their descriptions of cultural norms – for instance, while most respondents felt that those who are to be married, both girls and boys, should have some say in the decision about their marriages (including at least the right to refuse a potential marriage partner), this was described as being, and found to be by researchers, less likely to happen in reality. Secondly, cultural norms are not fixed: people living in the same community and from very similar backgrounds are shown to have widely varying opinions on what the prevailing cultural norms are. Thirdly, in recent years there have begun to be changes in how children are included in the processes for making decisions about their marriages, and with this in mind there are then opportunities to bring about further change in the levels of influence that children exert over decisions about their own marriages. In doing so, it may be possible to create an environment in which there are more aspects of choice and less of force in relation to marriage.

27 In this report the term “children” is used in reference to position in the family and does not imply that those being talked about are under the age of 18.

5.1 Understanding forced marriage in Afghanistan

A significant amount of attention is often paid to the notion of forced marriage in Afghanistan,²⁸ while less attention is given to understanding what constitutes a forced marriage and what causes forced marriage. This section argues that the notion of “forced marriage”, while perhaps a useful tool for advocacy organisations aiming to prevent violence against women or promoting that men and women only enter marriages to which they have given free and informed consent, is a less useful concept for understanding the manner in which marriages are decided upon in the Afghan context.

The archetypical notion of a forced marriage and the image that the expression “forced marriage” conjures in the imaginations of many is of a young girl being forced into a marriage, usually to a much older man. It is also commonly used to refer to marriages that are seen as abusive, violent and or illegal.²⁹ If a girl had no say in her marriage or if she did not want to get married or to be married to a particular man, but in the end the marriage is relatively non-violent and described as happy by the couple, and they are closer in age, it is rare that this is highlighted as a forced marriage. A number of respondents in this study described their marriages as forced but also described themselves as being happy in their marriages now. The questions, therefore, must be asked: is forced marriage only seen as a problem if the marriage is violent, the wife is abused or the man is considerably older than the woman? Is it only girls who are forced into marriages against their will?

28 For example, President Karzai’s speech on 8 March 2008 in which he “called on his countrymen to stop forcing their under-aged daughters to marry” (Afghanistan News Centre, 8 March 2008, <http://www.afghanistannewscenter.com/news/march/mar82008.html>).

29 For example, see the stories provided after a brief discussion on forced and child marriages in Amnesty International (“Afghanistan: Women Still Under Attack – A Systematic Failure to Protect,” ASA 11/007/2005 [online], 2005). In these examples there are either extreme age differences between the couples (36 years in one case) or the husbands are described as becoming particularly violent.

As well as girls and women, boys and men are sometimes made to marry against their wishes, which can have detrimental consequences for both them and the women they are forced to marry. A family may also be forced by another family to marry a child against their will. Cultural norms often force individuals to marry their children in a manner that is contrary to their personal desires, and these different forms that a forced marriage can take were identified by a group of young men speaking during a focus group discussion in Bamyan city:

Sometimes forced marriage happens when the father of a boy comes to propose to a girl. If they like the girl, they will threaten the father of the girl if he doesn't agree. In this situation the father has to accept the proposal even if his daughter doesn't agree. Sometimes people threaten to kill the father of the girl, and so he has to agree to the proposal.

— Young man (1), Bamyan city

It is also forced marriage when someone brings a woman to [her husband's] home by force. Another form of forced marriage is when a father and mother marry their daughter to someone when she does not agree with it, or if they bring a girl for their son and he is not willing to marry her.

— Young man (2), Bamyan city

Force can operate in many different ways, including both physical force and the consequences of not fulfilling a request or demand being so dire that no real choice is available — for example, social pressure being exerted to such an extent that there is no option but to comply.

The standard definition for forced marriage is where “one or both of the partners cannot give free or valid consent to the marriage”³⁰ or “a family determining

who a daughter should marry without her consent.”³¹ However, it is important to recognise that a person may be unwilling to marry but still give consent for certain reasons. Consent may only be sought from a girl or boy once their family has already agreed to the engagement — leaving them no real option but to comply. Likewise, while a child may consent to a marriage, they may not have enough information about what marriage means, their future spouse or in-laws or the arrangements for the marriage for this to be considered *informed* consent. They may have been deliberately restricted from accessing such information, even when they are over the age of 16 (the legal age for girls to marry in Afghanistan).³²

Children may feel social or emotional pressure to marry a person they do not wish to marry or at a time that is not in accord with their own wishes. Minimal pressure may be exerted by their parents or other family members, but children may still not want to upset their parents by refusing a proposal that their parents deem to be good. Alternatively, social, cultural or familial pressure may be exerted to such an extent that a person will concede as there is no perceivable alternative. For these reasons, the role of children in decision-making in relation to marriage is better conceptualised as existing somewhere along a range of positions from choice to force. At one end of this range is the archetypal representation of forced marriage and at the other end marriages in which both spouses either choose each other or are happy and willing to give sufficiently informed consent to the marriage. The decision-making in relation to different types of marriages, arranged under situation-specific degrees of social and familial pressure, fall somewhere on this range between forced marriage and free and informed choice of spouse and timing.

31 Afghanistan Independent Human Rights Commission (http://www.aihrc.org.af/wom_rig.htm). Note that this definition only refers to a daughter.

32 Definitions of forced marriage recognise that those who are still children are not in a position to give full and free consent; for instance, see Amnesty International (“Afghanistan: Women Still Under Attack,” 15) where it is stated that “child marriages by definition constitute forced marriage, as a child cannot be considered to have consented freely.”

30 Stop Violence Against Women (http://www.stopvaw.org/forced_and_early_marriage.html). Similarly the United Nations Convention on Consent to Marriage, Minimum Age for Marriage and Registration of Marriages states, “No marriage shall be legally entered into within the full and free consent of both parties” (<http://www.unhcr.ch/html/menu3/b/63.htm>).

5.2 Consent – informed or forced?

We have this custom that whatever parents do, their sons and daughters must approve of it, even if they do not consent in their hearts.

– Young man, rural Bamyan

Despite there being a commonly held opinion in the communities where the research was conducted that children should consent to their marriages, it was found that asking children for consent – particularly, but not limited to, the case of girls – was often done as a mere formality. This quotation from Jalil, an older man living in rural Herat, illustrates how he only consulted with his son once the decision was made:

When I decided to engage my older son I selected my brother's daughter. I then talked to [my son] Ahmed, telling him that I had selected my niece for him and asking whether he wanted her. He was shy and said that this was up to me and my wife: "If you have selected her, for me it is no problem, it is good."

In a social order where obeying elders, particularly parents, is deeply entrenched as the correct way to behave, it is very difficult for a child, regardless of their age or gender, to object to a decision a parent has made for them. Many children will consent to marriages that they are not entirely happy with if they feel that not consenting will disappoint their parents or because doing so would go against cultural expectations. For instance, Yar Mohammad from rural Herat explained that he did not want to marry his cousin but that if he had not accepted the marriage, his father would have rejected him. He loves and respects his father and so felt compelled to agree to the marriage. His consent to the marriage could be seen to have been given by choice, even though he was not happy about it; for him the consequences of not agreeing at the time seemed worse than those of going through with the marriage. The pressure to consent to marriages is often even greater for girls, for whom there is less chance of exercising independence from the family and who are judged far more severely than boys if they go against their parents' wishes.

The ability of children to give informed consent even where parents are willing to include them can be constrained by other circumstances. Those getting married may have no knowledge of the person they are meant to marry, nor of their family. This is particularly the case for girls, who have more limited social mobility. Ironically, due to the fact that after marriage girls usually live with their husband's family, it is girls who need the most information – not only about their prospective spouse but also about the household they are being married into. Even where the prospective spouse is a member of the same family, this does not guarantee that much will be known about them or the household in which they live. Indeed, as is illustrated by examples found in Sections 4 and 7, parents themselves may have only very limited knowledge about the prospective individual themselves.

Even when a child is asked for their opinion but they disagree with the rest of the family, extreme pressure may be put on them to consent. This was found to be the case for both boys and girls. For example, Khnom Jan, an older woman living in rural Bamyan, explained that her father had asked her if she agreed to a proposal (her mother had died); she had said she did not. However, she went on to explain that after this her aunt and uncle had come to visit her and insisted that she agree to the marriage. In the end she had felt she had to give in to their requests and consent to the marriage. It should be noted that on first interviewing Khnom Jan, she had said that she was asked about her marriage, had met her husband and had agreed to the marriage. It was only on further probing during a second interview that it was revealed she had had little choice but to agree. Since Khnom Jan mentioned that her menstrual cycle had not begun at the time she married, it can be assumed that she was very young when she was asked about her marriage and was therefore not in a position to offer informed consent.

A crucial factor impeding children's ability to give informed consent is that at the time when their marriages are being decided on, many are too young to have a meaningful role in the decision-making process, even if that is made available to them. Although not impossible, as a number of cases from

this research demonstrate, it is extremely difficult to break an engagement once it has been agreed on and doing so can have detrimental consequences for both the couple involved and their families.

Organisations working in this area often release various statistics and statements about child marriages, however when considering issues of consent it is important to also take into account the age of children at the time the marriages is decided on, rather than only their age at the time of the marriage.

While it was reported in the communities where the research was conducted that there has generally been an increase in the average age at which people are getting both engaged and married, across all generations interviewed many people were engaged at very young ages.³³ It was not uncommon for both men and women in the older generations, as well as a significant number of those who were married more recently, to have been married by the time they were thirteen years old. However, all those spoken to about this felt, at least on an abstract level, that children should be married when they are older – somewhere between 15 and 20 years of age for girls and late teens or early 20s for boys.

Despite this stated belief that children should marry when they are older and that they should give free and informed consent to a marriage, the actions of respondents often did not bear this out. A clear example of this comes from urban Herat. Khalid, in his early 30s, is married to Shameegul, in her mid 20s, and they have two sons of five and two years of age (family map 13). They live with Khalid's brother, Baserat, and his wife, Zora, and their three

The age children are when their marriages are decided on and engagements made is *at least as important as when marriages actually happen*, particularly in regard to children being able to give free and full consent.

children – two girls and a boy. They are a reasonably economically comfortable family, with productive land, livestock and a truck. Both Baserat and Zora have had some schooling and are literate. Khalid and Shameegul were engaged when they were children: Shameegul was six years old and Khalid was twelve. Early on in the interview, Khalid made it clear when talking about his own marriage that he recognised the potential problems that can arise from children becoming engaged at a young age:

We are happy; I am a lucky man. There are a lot of people who get married without being willing to do so. When their sons are young, parents decide about their marriages; their parents get them engaged without their [participation]. When they [the spouses] meet each other, after marriage surely they will face some problems.

In this household it is not only Khalid who disapproves of getting young children engaged: his niece's mother, Zora, who was engaged when she was just three months old, expressed the opinion that this was wrong and said that she does not want the same for her own daughter. Shameegul, Khalid's wife, said that she is glad she does not have a daughter who could be engaged and married as a child, as she was.

However, later in the interview Khalid explained his plans for his own five-year-old son:

My little son, who is five years old, calls my brother's wife "mother-in-law" because I will engage my son with my niece in the near future. My niece is three years old.

When he was challenged on this contradiction, he brushed it aside by saying that if they do not want to marry each other when they grow up, that is fine and they can find a spouse to marry themselves. As this example makes clear, it is not the age at which children are married that necessarily influences how much choice they have in the matter; instead,

33 It should be noted that many people interviewed did not know their own age and were not able to say at what exact age they were married or at what age their children were married. Instead, people – women in particular – would at times point to a child in the house and say, "I was the same age as that daughter when I was married", or they would express how young they were when they married in relation to when their menstrual cycle had begun. The approximate age of respondents was often calculated using various facts gleaned from interviews.

it is the age at which the marriage *has been agreed to* that takes away a great deal of choice that they might otherwise have had about the marriage.

Overt participation in decision-making processes is not the only way that individuals are able to influence decision-making outcomes, and for older children influencing decisions about their marriages may not only be done through giving verbal consent. The reactions observed in a child to the suggestion of a marriage partner, or to the fact that a marriage will happen at a certain time, have the potential to be more influential than a verbal agreement to a marriage, which is often not genuine or heartfelt consent. Some mothers and fathers interviewed in this study reported looking into the faces of their children – both girls and boys – to see if they were happy at the suggestion of a particular marriage partner. Some fathers, knowing their daughters would feel compelled to agree to any suggestion of an engagement made by them, would ask another woman in the family to see if the girl is genuinely happy with the suggestion, as with this older man from rural Nangarhar:

No, their choice is not taken into account. I myself will not ask her, but I will tell my wife to find out her ideas. It is not usual in our culture to ask our daughters about their engagements.

This quotation is somewhat contradictory as to begin with, in line with his own interpretation of cultural norms, the respondent says it is not necessary to ask for daughters' opinions. But out of concern for his daughter's well-being, he reports that he asked his wife to seek her opinion. He is evidently attempting to conform to his idea of cultural expectations, while at the same time trying to ensure that his daughter does not marry against her will.

In an example from the same village, while the mother was not asked directly by her husband to seek their daughter's opinion on a marriage decision, she said that her daughter told her she did not like the boy chosen for her. In order to prevent the marriage, she told her husband that she herself did not approve of the marriage, and in the end the proposal was not accepted by her husband. The mother also reported to the research

team that when a second proposal came for this daughter she could tell she was happier about it from her expression and behaviour, even though she did not ask her daughter directly about it.

When women are sent to ask girls in the family about who they would like to marry or when mothers simply look for their daughters' unspoken reactions to proposals that come, it allows parents, when they so desire, to take their daughters' opinions into consideration without violating perceived cultural norms. While boys may be allowed more opportunity to protest a suggested marriage, the tactics of looking for unspoken reactions are also used by some families to see if their sons are agreeable or not, particularly when it is felt that they would be too reticent to state their preferences.

From these examples of where parents have tried to take into account whether or not their children were happy about a marriage proposal, it could be argued that in these types of cases there is less force in the marriages of children who do not actually give formal or verbal consent than those who do but who see themselves as having negligible alternatives.

5.3 Boys and forced marriage

Much has been written about the effects of forcing girls in to marriages against their will; however, there is a dearth of information about the effects on the individual and family when the same happens to boys. Throughout the interviews with respondents, it was very common for men to describe their marriages as forced. Some men were found to have taken out their anger and frustration at having been forced into their marriages on their wives and other family members, pointing to a link between men feeling that they were forced into a marriage and the violence perpetrated against their wives. Similarly (and as explored in Section 8, which focuses on polygamy), being forced into one marriage can lead some men to want to take a second wife of their own choosing. For many, it is not necessarily the woman selected for them that fuels their objection to the marriage but more the timing of the marriage. Several younger men

explained that they had wanted to continue their education or apprenticeships, but their families had insisted they get married. Cases were also found in which the family's fears that their sons would engage in sexually or romantically deviant behaviour had led them to get their sons married earlier than when the boy wanted to or to someone they were not willing to marry. In two families, sons had been married because they were "in love with" or were having some form of relationship with a girl who the family felt was not suitable, and so it was arranged for the boy to marry someone else in the hope that this would stop the relationship. In both of these cases, the men were reported to

be abusive and neglectful of their wives, and these boys' family members identified the way in which they had been married as the cause of the current levels of violence in their marriages.

Noria and Shafiq (the nephew of Abdul Fataa, whose family was introduced in Section 4) live in rural Nangarhar with their two children (one boy and one girl), Shafiq's mother and father, his brother and five younger sisters (family map 12). Shafiq and Noria are both in their early 20s. Shafiq's family are relatively economically comfortable. All the children in the household currently go to school and Abdul Ghalib, Shafiq's father, studied

until sixth grade, although his wife says that despite this he is illiterate. Snawbar, Shafiq's mother, has never been to school and is illiterate. They have 1 *jerib* of land in the village but the family's primary income comes from the flour mill owned by Abdul Ghalib and his work as a mason. Shafiq sometimes works in Iran and sends money back to the family.

Shafiq was engaged by his parents and his father's younger brother when he was ten and the family was living in Pakistan. His father-in-law requested that his daughter, Noria, be married to Shafiq in exchange for Shafiq's sister being married to his son. When Shafiq's father, Abdul Ghalib, was asked if he consulted with Shafiq about the marriage, like other parents he said no and that that was because Shafiq was too young to understand. Shafiq's mother, Snawbar, explained that they had waited until Shafiq had grown up to get him married. However, by then Shafiq had decided that he did not want to marry Noria. Snawbar explained that it was impossible for them to not go ahead with the marriage: "We are Pashtun and it would shameful for us to break the engagement." The research team first heard Snawbar speak about her

Box 1: Should children be able to influence decisions about their marriages?

I believe that every son should be free to marry whoever they want. My children can choose their wives by themselves; I have the same idea about my daughters too – there won't be any restriction. This will be by their own wish, but parents also have the right to think about the future of their children, so my wife and I will also play a role in their engagements and marriages.

– Middle-aged man, urban Nangarhar

Of course her parents should ask her, because this is her right. Also, Islam says that before you marry your daughters you must ask them if they are happy or not, then according to the daughter's decision you can make a plan. Even Islam says that before engagement, girls and boys should meet each other. But Afghan people never accept this.

– Young woman, urban Nangarhar

I don't want to meddle in my daughters' lives; I believe they should marry whoever they want to and I will agree, because I have had a hard life.

– Older woman, urban Bamyan

I will let them to choose the boy for their life; some people engage their sons and daughters when they are small. It is bad and against Islamic law; the boy and daughter must see each other before the engagement, and if they select each other then they will be engaged. I will follow the Islamic rules for my grandchildren's lives.

– Older man, rural Herat

son's marriage during a focus group discussion, when she explained how badly the marriage had affected her son:

It happened when my son was small; I engaged him with a girl. When he grew up he saw the girl and he didn't want to marry her. Nevertheless I married him with that girl. After the marriage he became sick for a long time, then we took him to the doctor and after a long time he got better. Now he is in Iran, he is not interested in coming home. He does not speak to me; he said to me, "You're a cruel mother and I won't forgive you." Now I am sorry that I engaged my son in childhood. I blame myself and I always advise people not to engage their children in childhood.

Both of Shafiq's parents said that when Shafiq is home (not in Iran), he and his wife have vicious arguments and he is violent to his wife — kicking, slapping and punching her. Sharifa, Shafiq's aunt by marriage, also described how unhappy the marriage is, attributing this to the fact that he was engaged as a child and married when he was a teenager:

My brother-in-law got his son married when he was still a teenager. Now he is very unhappy and he always goes to Iran. His wife and children are unhappy with him as he is never there... His parents decided about his marriage. His father exchanged his daughter for his son's bride.... [My nephew and his wife] do not have a good relationship; Noria is always sad and crying.

This example clearly illustrates two themes that emerged from this study: first and foremost that boys being pressured or forced into marriages they are not happy with can lead to them being particularly violent to their wife; and second, how it is important to consider the age children are when their marriages are being decided on, rather than just the age at which they are married. By the time he was married, Shafiq was old enough to make the decision that he did not want to marry Sharifa; however, the engagement had been made when they were both still young children, and Shafiq's family deemed it impossible to stop the wedding from going forward.

5.4 Personal opinions — cultural norms and a readiness for change

In the past people didn't ask their children, but in the future I will ask my children about their lives. As I said before, it is not our custom to ask them, but we hope this will change in the future. We now let our sons and daughters go to school to become intelligent, and through this knowledge our children will make their own decisions in the future. I am very hopeful that our people will change their ideas. I want my children to seek an education, and after that we will let them plan their own futures. We will guide them. This is my wish, but I am not sure we can adopt it, because right now in our society it is not our custom. I am illiterate, but I know if our people seek education, I am sure their minds will change. Look: my husband is educated, but it is just that he is under the pressure of his culture. So let's see what happens. We are very hopeful for the future, and I hope my children have successful lives.

- Woman in her early 30s with 5 young children, urban Nangarhar (Shereen, family map 8)

The divergence between perceived cultural norms and individual desires is clearly illustrated by the above quotation, as Shereen struggles to reconcile her understanding of the demands of cultural norms and her own desires for her children's futures. Many people interviewed during this study said that they believe those getting married — both boys and girls — should have a say in who their future spouse will be (box 1). Shereen's statement supports the notion that there is both a desire and a readiness for change in the communities where the research was conducted.

This position was found among parents — both fathers and mothers — in all eight research sites and in different families, regardless of demographic factors as economic status, education level or location of residence. However, there is a stark contrast between individual respondents' personal opinions and perceived cultural norms and expected behaviours. As referred to in the methodology section and as the quotation from Shereen clearly illustrates, this is the vexed situation that many of

the respondents identified with. The quotations in box 2 illustrate how respondents would say that their own opinions differed to what they saw as the cultural norms of their community that they feel they should comply with. Women reported that they had wanted to ask their daughters about their marriages, but if they had done so “people would laugh at them”. It should be noted that this was not only true in relation to decision-making processes about marriage but it emerged as a recurrent theme throughout the broader research on family

dynamics. The divergence between personal opinions and cultural norms can be seen both as an indicator that cultural norms are in flux and, more critically, as representing potential for change in the way in which decisions about marriages are made.

Not all those interviewed shared the opinion that decision-making about marriages should be more inclusive. A substantial degree of diversity can be found among the opinions held within one area

and among families that are very similar. The opinions of Ghulam Ahmad (family map 10) and Abdul Sabor (family map 14) and their families are an example of how people from similar socioeconomic groups living in the same community can have significantly different opinions. Ghulam Ahmad and Abdul Sabor are Pashtun men who are both around 50 years old and live in the same part of urban Nangarhar. They both live in compounds with a large number of their family members, and they both have a considerable number of children. Their actual household structures are quite different: Abdul Sabor has two wives and is the sole male head of household, while Ghulam Ahmad shares his home with his brothers and their wives and children. Both families can be described as poor. Abdul Sabor’s family has some land outside the city which is farmed by a sharecropper. Ghulam Ahmad has irregular earnings from daily wage labour. Neither of the men have had any education, but most of their children attend school.

Box 2: Personal opinion versus cultural norms

I think it is important to ask the girls, because it is their life and they will have to bear it. Unfortunately, among our people it is the custom that they don't ask girls, but I don't agree with this.

— Young woman, urban Nangarhar

[My sister] was crying in the beginning, because she did not want to marry yet. And it was far away in Shomali, so also because of that she cried a lot. But no one asked her about her opinion, because it is not in our custom to ask a daughter about her marriage. We ask our sons, but we do not ask our daughters... I think it is necessary to ask both, because not only boys are living and marrying. Girls also get married and they should also have the chance to select their life partner. I think it is bad custom that we have.

— Young woman, rural Kabul

In this village daughters don't say anything in front of their fathers when the fathers make decisions about their marriages. They never say yes or no; they say, "Our fathers are our owners", and they leave everything to their parents. My daughters were the same. When I asked my daughter she said nothing, so I told her mother to ask her. When she did, my daughter said, "I don't know. I am agreeing with my father as he is my owner and he doesn't want a bad future for me."...I think it is good for daughters to be independent, and no one should interfere in their decisions.

— Middle-aged man, urban Herat

It is better to ask, but none of our people do. So if we ask, people will laugh at us. Anyway, let's see what happens. My daughter is small now. We will make an arrangement for her marriage and my husband will not ask her. Nor will I, because this is not our custom. Parents know what is best for their daughters; they are thinking well for their daughters.

— Middle-aged woman, rural Nangarhar

Abdul Sabor is keen for his sons to have a significant role in decisions about their marriages:

I will let [my sons] marry by themselves, because they are the new generation. I will not interfere in their marriages because it is up to them who they marry... I will only be an observer to see the background and history of the family.

Regarding his daughters he holds a similar opinion, although he expresses this in a somewhat contradictory manner by indicating that he may have more reservations about his daughters choosing their future spouses:

It will be by [my daughters'] own choice, because they might choose someone for themselves. I will marry them into the kinds of houses that in future they will not have any difficulties in and their life will pass well... Yes, it will be by their selection.

Ghulam Ahmad holds a more conservative point of view:

No [I didn't ask], because it is not our culture to ask our sons about their engagements. Only the parents make the decision... No, I will not ask them [in the future]; it is not part of our culture to ask the boys about their marriages. Decisions about engagements are only made by their fathers.

He expressed this opinion even more strongly in relation to his daughters:

No, it is impossible. We do not even ask the boys about their marriages, so asking the girls is even further away.

Ghulam Ahmad's and Abdul Sabor's family members hold similarly contrasting opinions. Kamila and Sarwaro are the two women mentioned in the previous section who told the research team that they have no say in decision-making and it is their husbands who make all the decisions. Sarwaro is Ghulam Ahmad's wife and Kamila is his brother's wife. Both women also reported that their children will not be asked about their marriages, although Kamila did say that if others change the way in which they approach this in the future, her family may also ask their children.

Abdul Sabor's second wife, Sabrina, reflecting on her own experience of marriage, expressed a similar opinion to that of her husband:

My parents should have asked me, but unfortunately they didn't. If they had have asked me, I wouldn't have accepted, and I would have married a man I chose... Yes, why not? I will ask [my daughters and sons] because it is their life and not mine. They have to bear it, and I will marry them how and when they want.

It was common for women to reflect in this manner, criticising the way their own marriages were decided on and organised and asserting that they do not want the same process to be undertaken for their children. A further example of this is Nazifa (family map 15), who is 20 years old and lives with her mother-in-law, her husband and his younger brothers and sisters in a poor household in urban Kabul. She said that after her father died her brother continued to decide on his sisters' marriages without consulting them. She describes her own experience of marrying in this way:

My father said, "I am not a mordagaw³⁴ who would ask my daughter about her marriage." And if the daughter disagrees and cries for ten days, it doesn't matter to the father or the brother. They do not listen to their daughters or sisters crying; they marry them with who they want to marry them to. In the beginning I also cried, but no one listened.

Nazifa hopes the situation for her own daughters will be different:

Right now my daughters are small, but when they grow up and are old enough to get married I will ask them. And I will ask their father to let them make the decision about their own lives and futures.

Although many men were more likely to report that their sons' marriages would be similar to their own, some did express similar sentiments in hoping for change in the future:

³⁴ "Mordagaw" refers to a person who sells women for sex; it is used to imply that a man is not "protecting" the women in his family.

There will be a great change between my own marriage and that of my sons. Their marriage will not be the same as mine. My family exchanged my sister to me, but I will not do it like this. My sons will work and they will find money, and then they will arrange their marriages with their own money.

This man is in his mid 30s and lives in urban Nangarhar. He was married at a young age and at a time when he did not want to get married, as it meant he had to give up his apprenticeship. In the same way that these men and women predict change in their families in the future, many reported that change had already taken place in their communities and families (see box 3).

It is clear that this change in ideals about decision-making processes is relatively recent, as evidenced by the number of families who have already involved or are planning to involve their younger children in marriage decisions more than they had done for their older children. For example, a woman in a focus group discussion with older women in the rural area of Bamyan Province said that her elder daughter complains to her because she was not given the degree of influence in decisions about her marriage as her parents are now giving her younger sister. Similarly, in a discussion with younger women in Herat city, a woman in her early 30s explained that she thinks positive change has come about as her sisters will be able to have more say in their marriages than she did.

Box 3: Changes in decision-making processes

In the past people would give their daughters in marriage by force and according to their own wishes. But now you see that girls are getting married according to their wishes. They see their husbands before marriage.

— Older woman, urban Bamyan

At that time things were very different to now. Now boys and girls don't marry without seeing each other, or a boy will say to his parents that he will get married on one condition: that his parents bring him so-and-so girl... Nowadays boys don't feel shy saying this kind of thing to their parents.

— Middle-aged man, rural Bamyan

That time was a very simple time. At that time people did not know anything. Now people have become bright; their minds are brighter than before. Now people ask their children about their marriages.

— Older woman, urban Kabul

Before, the decision was made by the father and mother and only they were making decision. But they are talking with sons and daughters now. And they can meet each other. A few years ago if parents wanted to marry their sons and daughters with someone, they had to accept. They could not select each other before, but they can choose now.

— Older man, urban Kabul

I am happy that now it isn't like it was in the past... I was a child when I was married.

— Older woman, urban Herat

As with many aspects of social change, it is difficult to identify exactly what has brought about this development in attitudes toward decisions about marriage. It is highly likely that a combination of interlinked factors have come together at a point in time, facilitating a shift in social norms. As is the case for other aspects of change in perceptions of appropriate gender norms and behaviours, war, and more specifically associated migration and displacement, was identified by respondents as a strong impetus for their change in opinions and practice:

Migration had its effects on them and they learned from the people there to give their children a chance to select and make their own decision about their marriages... People learned from others; they learned from their life and experiences. They learned what is good and what is bad, and they changed.

— Young woman, urban Herat

The people saw the war and difficulties. They changed a lot. I remember at that time people used to give a 14-year-old girl to a 70-year-old man. There were marriages for money, and forced marriages were very common.

— Older man, rural Bamyan

A more personal story of how migration brought about a change in family relations was told by Laila, a woman in her mid 20s living in urban Herat. Her father's behaviour changed dramatically after his experience of living in Iran: he stopped seeking a bride price and allowed Laila to choose which of the men who had come to ask for her she would marry. While Laila attributes this change in her father's attitude to his spending time in Iran, she does not think it was only a consequence of observing different approaches to family life there; she said it also gave him with the opportunity to escape the influence of his family.

War-related displacement and economic migration have in recent years exposed Afghans to new ways of being, and these different ideas have been brought back to Afghanistan as people have returned to their homeland.³⁵ Respondents also reported that to a degree internal displacement had also broadened their world view. It is possible to surmise that the past few years, at least in the areas where the data for this study was collected, has been the first time in a generation that people have felt relatively settled and in a position to think about and plan for a future for themselves and their families.³⁶ These two factors work in combination: exposure to different ways of being and relative stability have created the opportunity for change.³⁷

35 AREU's research on second-generation Afghan refugees living in neighbouring countries and their experiences of return further explores the differences between life in Pakistan and Iran and life in Afghanistan (see M. Saito, *From Mohajer to Hamwatan: Afghans Return Home* [Kabul: AREU, 2008]).

36 It should be noted that since data for this study was collected in 2006-07, security has declined markedly in some of the research sites, particularly in Nangarhar Province. Given this, this change in attitudes and opinions may have stalled.

37 Deborah J. Smith, *Love, Fear and Discipline: Everyday Violence toward Children in Afghan Families*, (Kabul: AREU, 2008) explores in detail the factors contributing to changing attitudes toward raising children.

5.5 Conclusion — a chance for change

This section began by discussing the notion of forced marriage in the Afghan context. It argued that the elements of force and choice in marriages exist on a range from choice to force rather than marriages being strictly one or the other, and many marriage decisions contain elements of both coercion and personal choice for those getting married. It is not always straightforward to judge whether or not someone has given informed consent for a marriage. For instance, some who apparently consent may have had little choice in doing so as it is a mere formality; some may consent because they would rather agree to a marriage than upset family members; others may consent and be willing to marry but have no information about the partner or their family to really be in a position to give informed consent; and others may not be given the opportunity to consent or not but instead are able to influence the outcome of the decision in more covert ways. Furthermore, it is not only a person's age at marriage that should be taken into account when discussing forced marriage but also the age at which a marriage is agreed to or an engagement made, which is at least of equal importance. The sub-section then discussed the issue of boys being forced into marriages against their will and the consequences of this for their families, arguing that this can encourage a man to be violent to his wife.

The second part of the section discussed community perspectives on the role that children should have in decisions about their marriages. While many children are still married at ages below that described as ideal by respondents, people expressed a desire for children in their communities to have a greater say in decisions about their marriages, demonstrating that these subjects are open to discussion and change in accepted practices. The sub-section also showed that many respondents described their own opinions as being different from cultural norms as they perceived them. However, it was found that people living in the same area and from the same background can still have quite different opinions and perspectives on what their communities' cultural norms are. This provides evidence that not only are cultural norms interpreted differently by

different individuals but that they are most usually in a state of flux – not rigidly fixed and not agreed to by all members of the community (or possibly even a majority) – and as such they are open to change, given the right incentives.

6. The Marriage Decision – Fear and External Pressures

This section is concerned with the pressures that parents and families feel to get their children married at younger ages than they themselves describe as ideal and to do so, at times, in a hurried fashion. It is demonstrated that these pressures to marry children can lead to a lack of forethought in decision-making processes, which can in turn lead to devastating consequences for the two people involved – in particular the wife. Four key areas beyond the immediate family or household dynamics are identified from which pressure is exerted on parents to get their children married:

- pressure from members of the extended family beyond the household;
- war and associated displacement as impetus to marry children – for girls this may have been as a form of protection against sexual abuse and for boys to prevent them going to fight;
- a general anxiety that if not married young, children may fail to marry; and
- boys being married before they are ready because the household needs a girl to do domestic work.

Economic imperatives driving parents to marry their daughters sooner than they would prefer are examined in a broader discussion of bride price in Section 7, while the fear of boys being sexually deviant were explored in Section 5.

6.1 Family members “forcing” parents to get their children married

In the foregoing discussion on forced marriage, the issue of individuals being “forced” by their own parents or close household members into marriages against their will was considered. It was also found by researchers that parents can be pressured into marrying their children against their will by members of their extended family. This may be as simple as parents feeling it would be rude or disrespectful to refuse a proposal from members of their own family.

Gender and generational dynamics play a strong role in determining who in a family can impose a proposal on another member of the family. Older brothers can put pressure on younger sisters to marry their children to their children’s cousins. Similarly, as an older woman from rural Bamyan expressed when talking about how her daughter’s marriage was decided on, it is harder to resist a proposal from the family of a male cousin wanting to marry a female cousin:

When our relatives come and propose we don’t reject them. If a relative comes who could reject them, we can’t reject them, for [my daughter] is a woman.

This woman also expressed the opinion that she married all her daughters when they were too young and now regrets this.

In another example from urban Kabul, a woman in her mid 40s described how her own marriage was decided on:

My father-in-law is my maternal uncle. He came to our house and asked my parents to marry me to his son. My parents couldn’t say anything to him because he was older than them and so they married me with my cousin... No one from my family was in agreement. My mother said, “My daughter is quite young. She does not know anything about life and having a husband.” But my uncle said, “No problem, I am her uncle. My house is like her parents’ house and she will learn everything.” After that, my mother couldn’t say anything to him because my uncle is her elder brother and younger sisters cannot say anything against their elder brothers.

It should be noted that despite these examples where mothers felt their elder brothers had forced marriages on their children, people primarily believe it is better to marry a relative than a stranger” – it is argued that daughters are safer in the household of their aunts and uncles and that marrying a relative can minimise bride price demands. However, this is not always the case and some women spoke about their disappointment in having to marry a cousin, particularly if they knew them well:

One day I went to my uncle's house. After two days I came home and my sisters said to me, "Our father has got you engaged to Abdul." He is my uncle's son and I cried a lot because he was just like my brother who I was playing with.

— Middle-aged woman, urban Nangarhar

6.2 Fear of having an unmarried child during times of war and migration

The main reason for this is the civil war. Because of that, most families married their daughters at a young age.

— Young woman, urban Kabul

As the quotation above suggests, war and insecurity put pressure on families to marry their children in haste. Girls were often married to protect their "honour" and in a very rushed manner, as an older man from rural Bamyan explains:

We were migrating; we were going to Yakowlang when we received a message from Ahmad's sister to give the girls in marriage. The girls were old enough and something might have happened to them... We exchanged them in Yakowlang and did the nekah. We did their wedding party in their old and dirty clothes while migrating.

An older woman who now lives in urban Kabul describes a similar motivation when her son arranged the marriage of her daughters:

After a few months when we went back to Mazar my son told me, "Mother, I engaged your daughter with that family. As you know they are a very good family and you know now the situation is not good in Afghanistan. It is better to marry your young daughters."

It is unlikely that anyone would actually think that married women were less likely to be raped or otherwise abused during times of war; instead, it can be assumed that this desire to marry young girls was because it would be practically impossible to marry a girl who had been raped or perhaps that it would be easier to cover up the rape of a married woman. Similarly, by marrying his daughter a father or brother passes the responsibility for her protection onto another man. It may have also

been believed that a husband would be in a better position to protect his wife than a father with more than one daughter to look after.

In an example from rural Herat, a father explained that when his family was internally displaced during the years of conflict, the commander of the area where they were staying was deciding who the girls in the area would marry and when. To avoid the commander doing so for his daughter, he quickly married her to her cousin.

However, it was not only the marriages of daughters which were organised due to the exigencies of war and displacement. In Bamyan Province, a small number of families reported that they had married their sons in an effort to stop them going and joining the fighting. For example, an older brother had organised the marriage of his younger brother before he himself was married, as his brother had wanted to go and fight. This deviation from the cultural norm caused difficulties for the older brother, who was teased by others living in the same area for not being a "proper man" until he himself was married. In another example, a man reported that when he returned injured from fighting, his parents found him someone to marry to try to prevent him going and fighting again.³⁸

6.3 Fear of a child not getting married "soon enough"

As marriage is a central aspect of Afghan social life, whether to be married or not is simply not a choice that is available for most people. Parents can therefore feel enormous pressure to ensure that their children get married, and getting children married is perceived as one of the most important responsibilities parents have in relation to their children. The number of badly, and at times hurriedly, made marriage decisions is suggestive of the level of concern that some parents feel that if they do not accept a proposal for marriage, another

³⁸ It is not proposed that married men did not fight during the various wars in Afghanistan; instead this was reported to the research team as a strategy that families used in attempts to stop their sons going to fight.

one may not come along.³⁹ Also, as pointed to in the discussion of boys being forced into marriages in Section 5, in a small number of cases boys had been married before they felt themselves ready because they were “in love with” or having some form of relationship with a girl who the family felt was not suitable. It had then been arranged for the boy to marry someone else in the hope that this would stop the relationship. The concern that boys may become sexually deviant if they are not married young was expressed through ideas such as “We have to get boys married so they don’t commit a sin” or we have to marry them to prevent “something happening.”

Other respondents reported that the reason for getting their children married young was because they wanted to see their children married before they died, as Nowrozuddin from rural Herat related:

At that time [when I was married], my son was 5 years old. When my sister-in-law’s daughter was 3 and my son was 5, my wife decided to marry our son to her sister’s daughter... I agreed with them, because we had only one son and we wanted to see their wedding party while we were still alive.

While Nowrozuddin is only 35, the fact that both of his elder brothers had died makes this a more realistic fear than it might otherwise appear.

Others said that the reason they had married their children sooner than what might be thought of as ideal was because they wanted grandchildren, as an older woman from rural Nangarhar explains:

As you know I have one son, so I wished that my son would get married because I wanted to see his children. I didn’t have enough money for my daughters’ marriages, so I exchanged my daughters.

6.4 Needing a daughter-in-law for domestic work

It was reported by several respondents that a mother, because she was the only woman at home and needed help with housework, had married her son even though it was thought that he was too young to be married by the family or brought a daughter-in-law even though she was also perceived to be too young to be married. It was also reported that fathers had married a son if his mother had died and there was no woman left in the house to undertake domestic work. In one example, Latifa Bibi, who lives in urban Nangarhar, explained how she is too ill to work and so married her son when he was 19 to a girl who was 13 at the time, even though she believed them to be too young to get married. She now recognises that this marriage has led to further problems for the family as her daughter-in-law was so young:

Because Karima [Latifa Bibi’s first daughter-in-law] was still a teenager when she gave birth, her kidneys were damaged and she constantly complains about the pain. She and Gulali [Latifa Bibi’s second daughter-in-law] would argue about the housework: Karima used to say that she couldn’t do it because she was in pain and Gulali used to complain that I had to do all the housework by myself.

A similar example comes from urban Bamyan, as the father of the family explains:

Since my wife was alone at home and she couldn’t do the house chores well, we made the decision to get one of our sons married. We asked our elder son, but he refused to get married. Then we asked the second one and he said, “Whatever you do is acceptable for me.” So we got him married.

That marriage proved to be highly problematic, and the daughter-in-law had returned to her parents’ house.

³⁹ For examples, see section 4 which describes marriages where the families knew very little about the spouse prior to the marriage. Other examples of this were found throughout the research in the different provinces.

6.5 Conclusion – fear as a catalyst for early and rushed marriages

This section has discussed some of the reasons for parents marrying their children in ways which they themselves think are detrimental, including:

- when their children are too young;
- without their children's opinions being taken into account; and
- without knowing much about the prospective spouse or their family.

Fear has been identified as a clear factor in this contradiction between what some parents state they believe is right and what they ultimately decide in relation to their children's marriages: fear of what will happen to their children if they are not married at times of insecurity and war; fear of sexual deviance; and the fear of parents not seeing their children married or their grandchildren before they die. A final reason identified for children being married too young is the practical need to have a daughter-in-law in the house to do domestic work. The section that follows illustrates through its discussion of the practices of bride price and exchange marriage that economic imperatives may also lead to girls being married at young ages and to people who the family may know little about.

Part 3: Marriage Practices

The third part of this report is concerned with a number of current marriage practices in the communities where the research was conducted: *badal* (exchange marriage), bride price and polygamy. There are other forms of marriage practised in Afghanistan that are not discussed below, primarily as little reference was made to them by respondents and as they are apparently much more rare.⁴⁰

Detailed information on how marriages are negotiated is provided, including what motivates families to choose particular marriage practices and what the outcomes of particular practices and negotiations are for the couple and their families. A number of case studies of families and the way marriages have been conducted within them are presented, but while these stories describe situations of conflict between husbands and wives, it is not suggested that the interests of men and women are always in opposition. Women may be placed in a subordinate position through the institution of marriage and even more so through particular marriage practices; however, as Jackson comments, “We should not lose sight of the shared interests of women and men in domestic groups.”⁴¹ Men and women undoubtedly have shared interests within particular families, and it is evident from the data collected that it is not only women who are suffering as a result of some marriage practices – so too are men.

There is not only a focus on what is reported to be happening within the communities but also on respondents’ own analyses of the situations, their

perceptions and their opinions on how they and their neighbours live their lives. There was considerable awareness found among many community members of different genders and ages of the potentially detrimental consequences of some marriage practices.

Section 7 deals specifically with *badal* (exchange marriage) and bride price. These two practices are discussed together as it was commonly reported that *badal* is used to avoid paying bride price. Section 8 discusses polygamous marriages, the range of reasons for men having more than one wife and the effect of this on his family.

40 For example, *khanadamad* and *bad*. *Khanadamad* is the practice whereby the husband lives with his wife’s family. This may be for several reasons; the one case of this that the research team found was in order for the husband to work for his father-in-law for a period of time rather than paying bride price. *Bad* is a practice in which girls are married to an opposing side in a dispute as a form of compensation or with the aim of bringing peace between the two families. A discussion of this practice can be found in AREU’s forthcoming reports on community-based dispute resolution.

41 C. Jackson, “Resolving Risk? Marriage and Creative Conjugality,” *Development and Change* 38, no. 1 (2007): 107-109.

7. Exchanging Daughters for a Bride, Exchanging Daughters for Money

Exchanging daughters in marriage (*badal*) is recognised by the communities where the research was conducted as a practice that perpetuates violence toward women in families. It was also said to be un-Islamic by some. Despite this, exchange marriage is one of the most common forms of marriage practised in the communities: marriages had been conducted by exchanging daughters in approximately half of the core households⁴² of the case study families where the research was conducted. Likewise, many respondents reported the negative consequences of the practice of paying bride price for both the girl and boy who are getting married, as well as for their families. However, alternatives to these practices were rarely suggested or acted on.

This section begins by telling the stories of two families whose daughters were exchanged as wives for their sons. These stories illustrate how this process of exchanging girls in marriage can create a vicious cycle of violence directed toward the women who have been exchanged. Examples are provided from other families in further examining the dynamics of exchange marriages as well as the rationale and motivations for families to choose such a form of marriage for their children. The following sub-section discusses people's opinions on the practice of exchange marriage, showing that while exchange marriage is accepted, widely practised and seen as a normal way to marry sons and daughters, is not entirely acceptable – it is recognised to be a practice which can lead to many problems in the future and is used because it is felt that there are no viable alternatives.

The second part of this section discusses bride price, highlighting how economic concerns for the family's overall livelihood and need to raise bride price for sons' marriage are put before the well-being of daughters. The way in which the demands for bride price impact upon the dynamics between the girl who is married and her husband and in-laws is also explored.

⁴² The "core households" are those where at least two people who permanently live in the household were interviewed.

7.1 Exchange marriages – case studies

Case study 1: Bamyán city

Parween and her husband, Baser, have five children (family map 9). They live with Baser's younger brother, Ishmail, his wife, Malika and their four young children as well as one unmarried brother, two unmarried sisters and Baser's parents. Ishmail and one of Baser's sisters work for an NGO and are often away working in a neighbouring district. With the income from these two children and land that is farmed by sharecroppers, it is an economically comfortable household. They have recently bought a car. Members of the family are relatively well educated: Baser's sisters studied up to grade six, his younger brother is in grade 8 and all the children in the family go to school. Neither Baser nor Ishmail attended formal school, but they studied at home and are literate. Their wives did not attend school, but Malika recently began to teach herself to read and write, with her daughters' help.⁴³

Parween and Baser were married when they were 9 and 19 years old respectively. They are related: Baser's father is Parween's mother's maternal uncle. Despite this, the families did not know each other well when their marriage was planned. As this was an exchange marriage, Baser's sister was married to Parween's brother at the same time as Baser was married to Parween. Parween's mother had come to Baser's house to propose the marriage, and Baser had agreed to the marriage without seeing his wife. He said that he was, at the time, concerned about whether his future wife would be beautiful and of good character, but since he liked her mother he felt he could trust that his future wife would be good too. His sister, who was 15 at the time, was not happy to marry and certainly not happy to agree to a marriage with a man she had not met, and Baser did not want his sister to get married at that time and without knowing the family well. While members of this family expressed their outward belief that girls

⁴³ The story of Malika deciding to educate herself is discussed in Smith, *Love, Fear and Discipline*.

should have a say in their marriages, it was evident that Baser's sister's objection to her marriage was not taken into account.

Although both Baser and Parween reported that Baser is now no longer violent to Parween, during the early years of their marriage he was, as were his brother and father. Both Parween and Baser attribute the cause of this violence to their being married through an exchange of girls, as these quotations illustrate:

I was married through an exchange marriage with my sister-in-law; my sister-in-law is living in [another village]. She was sending bad news to her mother [my mother-in-law] here and she was complaining that her mother-in-law [my mother] was locking everything away from her and not even giving her food. She was also saying that her husband [my brother] was beating her. My mother-in-law was saying to me that I was encouraging my brother to beat her daughter there, so this would all cause my husband to beat me.

— Parween

Since she was exchanged with my sister, whenever the situation was not good in their [my sister's] house, it would affect our house as well... Whenever my sister was beaten there for anything, my mother would also put pressure on my wife and she would fight with her saying, "Why are you free and my daughter is living under pressure from your parents?" I was forced to be involved in this matter and I had to beat my wife with shoes or whatever because I would get emotional about my sister. In fact I was asking myself, "Why should what was happening to my sister happen in our house?" But then I would beat my wife to release my tension.

— Baser

[My sister] would weep whenever anyone came to take her back to her [husband's] house. Her weeping would make everyone in our family sad and then I would kick my wife for my sister.

— Baser

There are three key points that emerge from these quotations:

- Violence against or mistreatment of one woman married through an exchange marriage is met by violence against or mistreatment of the other exchanged wife, and as a consequence a vicious, self-perpetuating cycle of abuse directed at the two women persists.
- Men's violence often is blamed on women — either the woman who is the victim of the violence herself or, as in this case, another woman.⁴⁴ Baser blames his violent behaviour on his lack of control over his own actions as well as the pressure that his parents, particularly his mother, had put on him to be violent toward his wife. Parween supports this perspective by attributing the cause of Baser's violence to what his mother had said to him.
- An exchanged wife may, at least initially, be seen as connected more to her natal family than to the husband's family, and therefore harming her is a way of taking revenge on her natal family for their treatment of the husband's sister. Baser was concerned about the situation his sister was in, and yet the only recourse he felt he had was to attack his own wife — who herself was in the same situation. This sameness in treatment of the two daughter-in-laws is not only played out in terms of retaliatory violence; for example, at one point Baser's parents suggested that he divorce his wife so that his sister would also be divorced by her husband.

While not all of the blame for the violence in this family can be attributed to the practice of exchange marriage, it certainly exacerbated the situation or at least provided an excuse for it. Ishmail, Baser's brother, who was not married through exchange, was also violent to his wife, and Baser's mother had suffered terrible violence at the hands of her husband for many years of their marriage. It appeared that of all the married men in this family, Baser was the most willing to acknowledge the violence he had inflicted on his wife and to admit regret for doing so.

⁴⁴ This theme is explored further in D.J. Smith, *Challenging Myths and Finding Spaces for Change: Family Dynamics and Family Violence in Afghanistan* (Kabul: AREU [forthcoming]).

Case study 2: Rural Nangarhar

Naz Bibi and Torpeokai (family map 16), in their early 30s, were married in exchange for each other in their late teens; their husbands are of similar ages. Naz Bibi lives with her husband, Manon, their two sons and three daughters (all under the age of 11), her husband's sister and her mother-in-law. Torpeokai lives with her husband, Jalil, their two sons (four and two), her husband's sister, Jahantab (a widow), Jahantab's three teenage children and Jalil's mother.

Torpeokai and Jalil's household is poor; Jalil works as a driver and also farms a small amount of land that they own. Jahantab does tailoring work from home. Naz Bibi and Manon's household appears to be slightly more secure economically, but they still struggle to meet their needs. They own 3 *jerib* of land, and Manon does casual labouring work when it is available. Shakila, Naz Bibi's sister-in-law (her husband's sister), had been working for an NGO, but that work had recently come to an end. All the adults in the families are illiterate.

It was Jalil's family who first proposed the exchange marriage. Some members of Manon's family were not happy with committing to an exchange marriage, particularly because Manon's father's first marriage was an exchange marriage and it had been highly problematic. However, Seema Gul, Manon's mother, explains that it was economic necessity that led them to decide to go ahead with the proposal:

When I asked my father-in-law and brother-in-law for their approval, they both accepted. Even though they did not agree with the exchange marriage, they understood I did not have any money and therefore I had to do an exchange marriage.

Seema Gul, however, sees the practice of exchange marriage as un-Islamic and recognises that it can be detrimental:

It is not a good practice. The mullah says it is not good. I heard it on the radio from a mufti [religious scholar], who also said that it is a bad act. A good way to marry girls is to exchange them for money and not for other girls.

Jalil and Naz Bibi's mother now deeply regrets her children being married through an exchange, as she explains:

Actually exchange is not good, but what to do? We had to. I wish I didn't make an exchange marriage, because it is not for one day, it is a lifetime, and no one is happy from this marriage.

Both Torpeokai's and Naz Bibi's husbands are violent to them, and in Naz Bibi's case the violence has been relatively extreme. It is also evident that Naz Bibi's husband is a particularly brutal man who has been known to torture his children. Like Baser and Parween, Torpeokai, Naz Bibi and their husbands see the cause of the violence and abuse in their marriages as being rooted in the demands of sameness in treatment of the two women who have been exchanged and in the revenge taken by brothers for the mistreatment of their sisters. Jahantab describes how they hold Torpeokai to ransom to ensure that their sister is able to return and visit her natal family home:

We never let Torpeokai go to her father's house, because this is an exchange marriage. If my mother permitted her, my brother and I wouldn't let her go. If we let her go, then my sister would never come here, but if we don't let Torpeokai go, [Torpeokai's natal family] will be afraid... It is up to Naz Bibi's in-laws family: if they let her come to our house, we will let Torpeokai go to her father's house.

Jahantab and her brother use the expectation of sameness in treatment of the two exchanged women in attempting to protect their own sisters. Jahantab presents her brother's treatment of his wife positively and never admits he is violent to her in retaliation for the abuse his sister receives. Jalil himself is more willing to admit to his violence, and Manon is equally forthcoming in admitting to being violent to his wife. Both men are despondent about their marriages and seem resigned to the problems within them, which they attribute to the exchange marriage process:

Exchange marriage is a bad custom; actually exchange marriage is forbidden in Islam... The

bad result is that when there is a fight between me and my wife or when I hit my wife and Jalil and his mother and sisters find out about it, they do the same to my sister. Why do I beat my wife? Jalil also beats my sister... Exchange marriage means taking revenge; it does not mean marriage.

– Manon

I am fed up with my life; I don't know who made up this custom. Exchange marriage is a very bad thing; it means arguments, beatings and no respect. Exchange marriage means fighting for a lifetime. When I say something or hit my wife over some matter, they do the same to my sister when they find out. If they do not let our sister come to our house, then we will do the same.

– Jalil

Box 4: Opinions on exchange marriage

My relationship with my wife is still not good. People say that an exchange marriage makes the situation in a house bad. Actually exchange is not a good thing and it is forbidden in Islam... I hope to find enough money to marry [my sons] without exchange marriages.

– Young man, rural Nangarhar

My elder sister was not in an exchange marriage, so she didn't have fights and arguments in her house... Exchange marriage is bad. I have seen many people who have had exchange marriages have arguments and fights at home and divorce their wives.

– Middle-aged man, urban Bamyan

I will never exchange my daughters. When they have finished their education, I will get them married. It is not a good thing. I have seen in some families who have exchanged their daughters that in the end they leave each other.

– Older woman, urban Herat

Manon's wife, NazBibi, also attributes her difficulties to having been married through an exchange:

I am exchanged with my sister-in-law, therefore I have many problems... Because it is exchange, if one of the exchanged is sad the other girl will be put under pressure to bear the same kinds of problems. I know it is very difficult, but what to do?

Because of their own negative experiences, both Manon and Jalil, along with many other parents interviewed, are adamant that their children will not be married through exchanging their daughters for daughters-in-law. However, this resolve may ultimately be overridden by other, external factors: as described above, Manon's father was also initially of the same opinion but was persuaded otherwise by his wife and by economic necessity.

This second story, while further demonstrating that exchange marriages can be a precursor to a cycle of abuse and violence, also illustrates how – despite all family members being opposed to this form of marriage and recognising it to be detrimental and un-Islamic – social pressures to get sons married, combined with the economic demands of bride price, can lead to the feeling that there is no alternative but to marry children in this way.

7.2 Attitudes toward and reasons for exchange marriage

Along with the two featured case studies from Bamyan city and rural Nangarhar, researchers found many other instances of exchange marriages among respondent families that had resulted in the same self-perpetuating cycle of violence and abuse toward the women involved – in fact, it is an outcome of exchange marriage that is recognised by all of the different groups interviewed in all research sites (see box 4).

Violence toward a daughter-in-law because her husband's sister is being abused by her own in-laws is so normalised that women sometimes use it as a threat in attempting to protect themselves

from violence, as this young woman living in rural Nangarhar explains:

At that time I cried a lot because my whole body was in pain. I said to my mother-in-law, "Do you feel good now? Look, he beat me, and I will tell my mother to beat your daughter because your son beat me without any reason."

It is not only in terms of injurious treatment toward women, along with separation and divorce, that sameness in treatment of the two women who are exchanged is expected. There is also the expectation that if one of the women is bought a gift or clothes by her marital family, the same should be done for the woman she was exchanged with. In many cases the lives of the two women who are exchanged remain bound to each other.

On occasion, however, it was reported that women had broken free from the expectations of sameness in their exchange marriage. A woman from Bamyan city had successfully resisted being divorced from her husband when her brother divorced his wife, her husband's sister.

In both of the case studies discussed in the previous sub-section, the most common form of exchange was used — women being exchanged for a bride for their brothers. However, exchanges can also be between different family members, such as fathers exchanging their daughters for a young bride for themselves. In one family in rural Herat, many exchange marriages had been made across the generations. Shazia, in her mid 40s and the oldest woman in the family, explained that she was exchanged in marriage as a very young child for a new bride for her father; however, it was not possible for the research team to explore her father's rationale for doing this as he had since died and Shazia did not appear to know why he had done this. While there were no other examples of this happening among other case study families, it was mentioned occasionally in focus group discussions, so the research team was able to establish that while it happens, it is not very common. Those who did talk about it strongly disapproved.

A father exchanging a daughter for a new wife for himself can encourage the marrying of very young

girls. In other examples found during the research, exchange marriage resulted in the marrying of both boys and girls very young, because one couple in the exchange would be "old enough" for their parents to want to marry them but the other couple would still be young children. In some cases it is agreed that the younger couple wait to get married. However, once one couple has married pressure may be put on the younger couple to marry, regardless of what the agreement might have been. If a girl is not married at the same time as the girl she is being exchanged with, the family whose daughter has been married may ask for a relatively low bride price as compensation for losing their daughter but not immediately receiving a daughter-in-law.⁴⁵

This research has established that exchange marriage is a very common marriage practice, despite the fact that there is a great deal of awareness about its likely negative consequences. This contradiction in opinion and behaviour can be explained by a combination of factors.

Lack of options

Paying bride price or conducting an exchange marriage is seen by families as the only means by which to marry their children. The most common excuse given for marrying sons by exchanging daughters is economic necessity. Despite clearly recognising the risk of future difficulties resulting from exchange marriages, families are often resigned to having to marry their children through exchange.

It should be noted, however, that families feeling they are not able to afford to pay a bride price may be relative to their lifestyle and the bride price demands among their social group. It is not only the poorest of families who use exchange marriages to marry their children, and not all of the poorest families use exchange for all marriages. Baser and Parween's family, for instance, are one of the wealthier families in their community.

⁴⁵ For details of a serious conflict which has arisen due to this type of arrangement, see D.J. Smith and S. Manalan, *Case Study: Community-Based Dispute Resolution in Nangarhar* (Kabul: AREU [forthcoming]).

Pressures to get children married

As discussed in Section 6, a range of external pressures may lead families to organise the marriages of their children at a time and under circumstances that may not be in line with their ideal hopes and desires for their children.

Priority given to sons' marriages

While parents recognise that their daughters might suffer very badly if they marry them through an exchange, ensuring sons are married can sometimes take priority over this concern for daughters. Salima, a young woman living in urban Nangarhar, recognised that her brothers' needs were put before her own:

We were poor and my father didn't have any money to marry my brother, because as you know if families want to marry their sons, they should have money... But my father was poor and my brother didn't have money, so my father exchanged me even though I was small. But what to do? I don't have a single elder sister.

This prioritisation of sons' needs over those of daughters can also lead families to marry their daughters younger than they would ideally desire because an older son is at an age at which they wish to marry him.

7.3 Bride price

When people give birth to a daughter they look very upset, but when they give birth to a baby boy they look very happy and they arrange a party. But when they marry their daughters, the parents take money from their daughters' in-laws, so they become happy. It is common, then, that in some families there are many arguments and fights... At that time they feel sad because their daughters are in trouble.

— Young woman, rural Nangarhar

As with attitudes found toward exchange marriage, people are generally aware of the negative impacts of the practice of paying bride price, despite its widespread use. The detrimental consequences of bride price to which respondents pointed include: the

way in which bride price may motivate or influence families to make decisions about their daughters' marriages, with economic concerns overriding the well-being of the daughter being married; the economic consequences for the man who is being married and his family; and the treatment of a woman by her in-laws when she is first married, reflecting their response to the amount of bride price they have had to pay for her.

As with exchange marriage, bride price is widely accepted and practised by many. However, despite this it is not entirely acceptable to all. For instance, a young woman from rural Nangarhar explained that she sees bride price as un-Islamic:

Islam forbids [taking bride price] and says that those people who give money will go to hell. Also Allah and Prophet Mohammad hate the act of taking money, but unfortunately our people don't pay attention to this and they think it is good. But a minority of people do not take money.

For some, the taking of bride price is acceptable if the money is then used to buy particular items for the girl getting married to take with her to her in-laws' home, in order to make her more comfortable:

In my opinion the bride's family must take a little money, then her parents should spend that money on her. I think this is a good solution, because as you know people have economic problems.

— Young woman, urban Nangarhar

A very small number of parents mentioned spending the money they received as bride price on their daughters, such as the following middle-aged man from a relatively economically comfortable family living in rural Herat. He has four young daughters, one of whom was recently married, and he describes how he spent the bride price received for his daughter:

I got around 160,000 Af\$ from my son-in-law, but spent all of that money on my daughter. This is a tradition in the village that when the father gives his daughter to someone, he spends the

bride price on his daughter. The father should buy all the house equipment like dishes, cooker, carpet, clothes, blankets, boxes and teapot.

There may be an element of idealisation or exaggeration to this statement, but at least it is a representation of what he sees as ideal and acceptable. This man's wife reported receiving a far higher bride price for their daughter, and when asked how her husband is making a living she said that for now the family is living on the money from her daughter's bride price.

Using bride price to meet the basic needs of the family was reported by others. For example, Bakht Bibi, who lives in urban Herat and whose family has always been desperately poor, is married to a man who is blind and has other disabilities and is unable to work. For most of her married life, Bakht Bibi has had to work in other people's houses washing clothes, baking bread and more recently as a *daya* (traditional birth attendant) to support her family. She reports that she married her first three daughters through exchange in order that her three eldest sons could be married. For the next two daughters she has taken bride price, receiving between 500,000 and 600,000 Afs, which she says provides the family's current livelihood. In this example, decisions about marriage practices have formed part of the family's wider livelihood survival strategy.

For others, bride price had deliberately been sought in response to economic shocks to the family. For example, Aziza (family map 17), a 23-year-old woman from rural Herat, was married when she was in her mid teens to a man from Balochistan who lives in Iran. Aziza estimates that her husband was about 60 when they were married. Both Aziza and her mother recounted that Aziza's father was sick at the time and they could not afford to pay for his treatment. The man from Balochistan was rich and could pay a high bride price, so Aziza was married to him to raise the money for her father's treatment. Both Aziza and her mother reported that their family knew very little about the man prior to Aziza being engaged to him, including the fact

that he already had five wives.⁴⁶ His ability to pay was the family's primary concern. Aziza suffered extreme physical and psychological abuse at the hands of her husband. Her *ambagh* (co-wives) were also abused by their husband (the relationships between Aziza and her *ambagh* are explored in Section 8).

Jamila from urban Nangarhar also reported that her brother married two of their sisters to unknown men in order to raise money for the treatment of their brother's drug problem.

It is clear from both individual family stories and more generalised data collected during focus group discussions that collecting bride price can be a key livelihood survival strategy for girls' families. Similarly, the livelihoods of boys' families are equally affected by having to raise bride price. Several examples were found where families' productive assets had to be sold to marry a son or brother. Many men travel abroad to either Pakistan or Iran to work for a number of years to raise the bride price for their own marriages (this was particularly common in Herat Province). This impacts on the household's structure, with adult men leaving the household for extended periods of time. Some respondents also reported that their families had been in debt from raising bride price.⁴⁷

The paying of bride price, particularly when the price demanded is relatively high or increases over the period of the engagement, can make the boy's family bitter and angry toward the girl from the moment she comes to live with them. In one instance, Jamila, who is married to her paternal cousin, is in her late 30s and has had 16 children, however only seven of them have survived past infancy. Her husband is disabled and unemployed; they rely on handouts from her brother-in-law and money that she earns from the few animals they

46 This is the only case the research team found of a man having more than four wives, which is not acceptable or generally practised in Afghanistan. Since this man and his direct family were not spoken to, it is not possible to know how he justified having more than four wives.

47 See AREU's reports on debt and credit for further information on this, including F. Klijn and A. Pain, *Finding the Money: Informal Credit Practices in Rural Afghanistan* (Kabul: AREU, 2007).

keep and some tailoring work she does. They live in a very small, run-down house in urban Nangarhar. While Jamila says that her husband is mentally ill and that his violence has increased since he lost both his legs in an explosion, she also explains that her husband says his violence toward her is directly connected to her father having demanded a high bride price for her:

All my in-laws were upset with me. They said, "Your father took so much money, but he didn't spend it on you." Thank God they are relatives. ... One day I said to my husband, "I am alone all day – will you buy me a tape recorder?" He said, "Your father took lots of money from us. Tell him to buy it." When I went to my father's house, I asked him and he bought it for me. When I came back to my husband's house and played the tape recorder, my husband beat me badly. Usually when he beats me, he says, "Your father is cruel. He took all our money, and it is because of this that I have become upset." Sometimes I want to commit suicide... [My father-in-law] still owes 20,000 Afs... Last week my father said, "I need 20,000 Afs. Should I take it from your father-in-law?" I said, "No, please don't, otherwise when my husband comes home he will beat me."

While the violence experiences is severe, it is unfortunately typical of the way in which bride price demands may be held over a woman once she is married, often more so in the early months and years of marriage. An extreme example of the way in which a family may see a new bride as intrinsically linked to her bride price was related by an older man speaking during a focus group discussion in Bamyan city:

I know a family who spent 60,000 Afs on their daughter-in-law, and they used to call her by the name of "60,000 Afs".⁴⁸

Bride price contributes to a family's feeling that they own a son's wife and have ultimate rights over her, as the quotations below illustrate:

Her in-laws think we spent a lot of money on

our daughter-in-law for her wedding, so they have rights over her and her father doesn't.

— Older woman, urban Nangarhar

The mother-in-law would say to her daughter-in-law, "I have bought you with money and I have paid much money to do so. Why are you late?"

— Middle-aged man, urban Bamyan

While these negative impacts of bride price are widely recognised, it is still commonly practised. Therefore, it is important to ask why the practice continues. One reason might be that while bride price is recognised as a cause of difficulties for newly married daughters-in-law, there is an expectation and despondency about the fact that whatever happens a newly married girl will face problems: she will be abused and constantly put under pressure. A young woman from rural Nangarhar explains this in the context of parents thinking only about the present and not about the future consequences of their decisions:

Unfortunately, parents are not paying any attention to the future lives of their daughters; they just think about the present. Parents say that every daughter faces problems at the beginning [of her marriage] and that after a few years they will be happy with their life... But I do not agree with this custom.

A further reason may be that while it is recognised as a contributing factor to the abusive treatment of some daughters-in-law after marriage and that for sons' families it can present a huge economic burden, for the families of daughters there is also significant economic gain to be had. Finally, families both lose and benefit in the cycle of bride price payments, and taking a stand against bride price – without wider community agreement – is something that is difficult for individual families to do and still be able to marry their sons.

7.4 Conclusion – a lack of viable alternatives

This section has described the negative consequences of the practices of exchanging daughters for a wife

⁴⁸ It should be noted that this was something that was reported as having happened in the past.

for sons and exchanging girls for money, or taking bride price. The research team's understanding of these negative consequences emerged directly from its discussions and interviews with members of the communities where the research took place, and for this reason it is clear that people in those communities – both men and women – are well aware of the potential detrimental outcomes of conducting marriages in these ways. At the same time, respondents rarely posed viable alternatives or ways in which they could break out of the cycle of paying for girls or exchanging them. Similarly, while it is that for some families bride price is used as an economic survival mechanism and a way to raise a bride price to marry their sons, and while exchange marriage remains one of the few options

for families that cannot or do not want to pay bride price to marry their sons, it is difficult for individual families to take a stance on these issues that might provoke broader change. Furthermore, the local economies of communities are probably so entrenched in bride price payments that it is even harder to break the cycle of giving and receiving bride price.

More positively, the awareness that community members demonstrated in relation to the negative consequences of these marriage practices does allow them to be openly discussed and for possible ways to break the cycle to be identified by the communities themselves.

8. Polygamous Marriage

I do not agree with having a second wife, because their husbands can't give them their rights. Sometimes if a man doesn't have children he can [marry again], otherwise it is not good to collect wives in the house. They will make arguments at home, so it is better to have only one wife. Allah said that you only have a right to marry again if you can make a balance between [your wives]; otherwise, it is better to have only one. Of course it is very difficult to make a balance between them, so Islam also prefers one wife.

— Young woman, urban Nangarhar

As the quotation above illustrates, a man having more than one wife is viewed by the communities where the research was conducted as, at the least, a difficult family dynamic to manage. It is commonly associated with destructive family relationships and violence, and, as the quotation infers, it is considered by some as un-Islamic — particularly if it is not practised in a certain manner. The quotations in box 5 provide further examples of individuals' opinions on polygamy. The main reason for disapproval of this practice is the potential it is seen to create for conflict in the family. It is interesting to note how aware some respondents

were that this conflict between adults in the family can have a detrimental effect on children. Given that there is wide-scale acknowledgement of the potential detrimental consequences for a family when a man is married to more than one woman at a time, the stories presented in this section highlight that compliance with perceived cultural norms and expected gender behaviour can lead to people living in family structures that they knew would be likely to be problematic before they entered into them.

Some respondents stressed their disapproval on moral grounds, as does this middle-aged woman in describing a young man who refused to marry again despite encouragement from others:

Box 5: Opinions on polygamous marriage

It is not acceptable among the people [to have more than one wife].

People ask why that man has two wives. It is bad to have [more than one] wife in this area.

The man who has two wives has a bad life because there are disputes in his house. He brings his second wife so that he can improve his life, but having two wives deteriorates his life... People consider it bad when someone has two wives, and they ask why he has brought a second wife when he already had a wife.

— Young women, rural Bamyan

I was considerate of [my wives'] rights; when I bought things for the elder one, I also bought for the younger one. I visited them in turn. I always endeavoured to keep them happy. But I think that having a second wife is not good; it has a bad effect on the children.

— Older man, rural Herat

Having two wives has a bad effect on the children, because they see the fighting between mothers. When the children go out they will then fight like this with other children, and when these children get older it has a very bad effect on society.

— Middle-aged woman, rural Nangarhar

If a man marries again, it has a very bad effect on the family because it creates arguments between the children, between the two wives and with their husband. For example, if a husband "talks" with his second wife, I am sure his first wife will feel jealous or they will fight over housework.

— Young woman, rural Nangarhar

I'll tell you the story of my relative. He was very young and handsome, but his wife was older and ugly ... All our relatives said to him, "You are handsome, but your wife is ugly. Why don't you get married again to a young beautiful girl?" But he said, "I will never marry again, because when I was a student and had nothing to eat she was with me. Now I am rich, I will not get married again – no, never." But we know lesser men who don't know the rights of their wives.

Similarly, the father of the young woman from urban Nangarhar quoted at the beginning of the section took a stand when the family of a man who already had one wife came to propose for one of his daughters:

One day a family came to our home to propose. They said they were going to marry their son again. My father asked them, "Why do you want to get him married again?" They said, "Because our daughter-in-law is not clever and she is unhealthy – all the time she is sick." My father told them, "You should take her to a doctor. And you can leave my house now!"

Given this generally negative attitude towards polygamous marriage among both men and women, young and old, this section outlines the four primary reasons reported by respondents for why a man marries a second, third or fourth time:

- a man's current wife or wives have either had no children or have not had any sons;
- a male relative dies and an already married or engaged man in the family marries his widow;
- a man or his family is dissatisfied with a first wife (particularly in cases where men felt they had been forced into their first marriage); and
- difficulties encountered during a first engagement and a considerable delay in the marriage happening, leading a man to take another wife before he marries the first woman he was engaged to.

Respondents did not give examples in which a man's wealth was the reason he was married

to more than one woman at a time. Instead, wealth was reported by a small number of respondents (both men and women) as something that might enable a man to treat his wives more equally and reduce the potential for conflict by being able to provide separate living spaces for his wives. Others pointed out, however, that wealth does not necessarily guarantee equality in the treatment of wives and cannot be used to justify the practice of polygamous marriage.

A number of family stories are presented to illustrate the ways in which polygamous marriages can come about. The relationships within the family are described, in particular those between *ambagh* (co-wives), and it is concluded that while in many instances there is conflict and rivalry between wives, in some cases these relationships can form an important source of support and cooperation.

8.1 Reasons for polygamy – infertility

A unanimous belief was expressed by respondents discussing the rights and wrongs and consequences of polygamous marriages that a man should marry again if his current wife had not borne him children

Box 6: Marrying again because of infertility

It is compulsory to get a second wife in this situation [when a first wife has not had a child].

– Young woman, rural Bamyan

From my point of view, if a man doesn't have children at that time it is good to get married again. But if a man doesn't have any good reason, it is not good.

– Young woman, rural Nangarhar

Some women cannot have children and the man is obliged to marry a second, third or fourth woman. As we all know, if you don't have children it will be very difficult to live in the future...sons and daughters should take care of their parents in their old age.

– Older man, rural Nangarhar

and to a lesser degree if a wife had not borne him a son (see box 6). Some female respondents said that the sex of a child was Allah's making and therefore it was not entirely acceptable to marry again if a woman had not produced a son.

There was some recognition that infertility can be caused by the husband, although this was not commonly talked about or acknowledged by men, as this young woman from urban Bamyan explains:

Men don't see themselves and they blame all the faults on their wives. There are some men [in this area] who are not able to produce children, but they have married for a second time. Now they don't have children from either wife, so they destroy the lives of both wives, but they never blame themselves. My neighbour has two wives, and neither of his wives has any children. He has destroyed the lives of both of his wives.

An exception to this was found in a case of a man investigating his own fertility status before marrying for a second time. Both the man and his first wife were reluctant for him to marry again, but he went ahead with it – suggesting that while undesirable, marrying another woman due to infertility may be seen as unavoidable. Several other examples were provided by respondents of first wives insisting that their husbands marry again because they had not had children. This case study also shows how a first wife may assist her husband to find a second wife if she has not had children and demonstrates that the need to have children in the family is so essential that a woman is prepared to share her husband with another woman in order to bring children into the family.

Case study: Rural Kabul

Arif, Maha Jan and Zari Jan live in rural Kabul with their two unmarried daughters; their two elder married daughters live in the same village (family

...compliance with perceived cultural norms and expected gender behaviour can lead to people living in family structures that they knew would be likely to be problematic before they entered into them.

map 18). Arif describes himself as unemployed, but he farms a small amount of land which he reports provides enough for his family's livelihood. The family has cows and it sells the yoghurt made from their milk. Arif had been in the army and he still receives a government pension. He has had some schooling and is literate. Both his wives are illiterate, but his daughters go to school.

Arif and Maha Jan (Arif's aunt's daughter) were married approximately 35 years ago when Arif was 20 years old and Maha Jan was between 10 and 15 years old. Similar to other examples provided in Section 4, Arif's family's motivation for marrying Arif to Maha Jan was because they need a woman to take care of the domestic responsibilities. They had been married for seven years without Maha Jan bearing children when Arif decided he should marry again. Arif did not lay the blame for their infertility on his wife; instead he sought medical advice before taking a second wife, as he explains:

I did not have a child for many years. I went to the doctor, because I thought if I am sick and my wife is healthy I should not marry again. I went to many doctors and the results showed that it was my wife who was sick, so I then married a second time.

Maha Jan's mother's sister approached Maha Jan and suggested her own daughter, Zari Jan, as a second wife for Arif. Both Arif and Maha Jan believed if Arif married Maha Jan's cousin, it would be less likely that there would be conflict between the two wives, and so the marriage was agreed to by both of them. Zari Jan, however, did not want to marry a man who already had a wife, and she particularly did not want to share a husband with her cousin:

I cried a lot and did not eat for a few days, but no one listened to me... I did not want to marry the husband of my maternal cousin and become ambagh to her.

Prior to this second marriage, both Arif and Maha

Jan reported that their marriage was not violent. However, shortly after the second marriage Arif became violent to both his wives. A catalyst for this violence was Arif's anger when it became apparent that Zari Jan was very ill — she was probably suffering from both typhoid and tuberculosis. It was also evident that she had some psychological problems. Arif accused Maha Jan of not informing him of her cousin's health issues prior to the marriage.

Both Maha Jan and Arif expressed regret that Arif had been compelled to marry again because they had not had children. Arif said he was disappointed with both of his marriages as he felt he had had little choice in either of them:

I was not happy about [both my marriages]. The second was a fraud; my second wife was sick. The first one was forced. I was very young and because we didn't have anyone at home my father decided to marry me and I accepted... I was not ready but I had to accept.

For the first three years of their marriage, Zari Jan did not become pregnant and Arif's violence toward both his wives increased. Arif blamed Maha Jan for the situation, as Zari Jan was her cousin and she played a role in organising the marriage:

When my husband returned home from work, he came to my room and I said, "Salam, how are you?" Instead of replying to me, he punched my back and said, "Shut up, stupid. Because of you I do not have a child. You married me with your cousin who is also like you, and she did not give me a child." He started crying, and when I saw my husband crying I felt sorry for him.

— Maha Jan

Maha Jan also reported that Arif's anger was fuelled by other people's gossip:

When we went out, people would talk about my husband, saying "Look at his age — he has become old and he has two wives but no children. I think he has a problem and it is his fault he does not have children." When my husband would come home he would become angry with me and start beating me.

After three years Zari Jan gave birth to a daughter, then a second daughter. Once Zari Jan had borne children, the violence in the family ceased. At around the same time the fighting between the mujahiddin and the Soviets intensified and the family, including Arif's father-in-law (who has since passed away), fled to Pakistan. Arif did not leave immediately with the rest of the family but stayed to fight with the mujahiddin. Maha Jan said that after the period of reprieve from their husband's violence following the birth of Zari Jan's first two

Box 7: Opinions on men marrying their widowed female relatives

When one brother dies and his wife becomes a widow, the other brother who has a wife is forced to marry his brother's widow because it is shameful in our society if he doesn't marry her. A Pashtun never leaves his brother's wife to marry another person.

— Middle-aged man, urban Nangarhar

I didn't want to have two wives at first. One of my brothers who lives with me died and his wife remained with us for five years. None of her relatives came to marry her, so I married her. It is a very big nang [shame] for us if someone else, a stranger, comes and marries our sister-in-law, and a person would take this nang to his grave — that his sister-in-law is married to someone else. I had to marry her.

— Middle-aged man, urban Bamyan

I did not want to marry again...it is very difficult for a woman to marry her brother-in-law because while her husband is alive she behaves with her brother-in-law like he is her brother. And when her husband dies she has to marry a person she had thought of as a brother. But I married him because of my children. If I did not marry him, my mother-in-law would have taken my children and kicked me out of the house.

— Middle-aged woman, rural Kabul

daughters, the level of violence returned to what had been before:

We moved to Pakistan. After that my co-wife did not give birth for eight years and we had the same life as we had had at the beginning of the marriage. I mean my husband was angry with both of us because a third child had not come... He started beating us again because we didn't have another child.

After the Soviets left Afghanistan and the family returned to their village, Zari Jan gave birth to two more daughters and again Arif's violence decreased. Zari Jan reported that while he is still verbally abusive to both wives, he is no longer physically violent to them.

It is clear that Maha Jan has much higher status in the household than Zari Jan. The research team noticed that she was always better dressed than Zari Jan, who often looked dishevelled. Maha Jan's role in the work of the household is also one of higher status: she is responsible for their productive assets and is free to go outside in the community. She explains that this is in part because she grew up in the village and everyone knows her, unlike Zari Jan who comes from another village.

The relationship between these two women as cousins is evident, with Maha Jan behaving more like an older sister to Zari Jan than an *ambagh*. She tells her how to behave and tries to protect her from Arif's violence, as this example shows:

One night my ambagh brought the deseterkhon [cloth laid on the floor for eating from] and put it down very crossly in front of my husband, me and my husband's cousin, who was also at our home. At that time my husband did not say anything, but when everyone had gone to sleep he got up, took a big stick, pulled Zari Jan to the other room and started beating her, saying "You're not getting pregnant after several years and you're doing these kind of things in front of my cousin – I'm ashamed because of you!" When I heard Zari Jan crying and shouting, I came to the room and tried to stop my husband from beating her, saying "Stop beating her or she'll die!" When my husband saw me, he left Zari

Jan and started beating me very hard, saying "Because of you, I have this wife!"

– Maha Jan

Maha Jan believes that Zari Jan is less supportive of her and that she does not try to defend her from Arif's violence. To a degree, she also blames Zari Jan for the violence as it began after Arif's marriage to Zari Jan. Unfortunately, the research team was unable to speak to Zari Jan without Maha Jan being present, so it was not possible to record her version of events. The fact that the team was unable to interview Zari Jan alone is illustrative of the power balance in their relationship – Maha Jan is a controlling force. Despite these inequalities between Maha Jan and Zari Jan, there is little overt conflict between them, and Arif acknowledges that the relationship between his wives is not like that of other *ambagh*:

They are not like other ambagh; as we all know ambagh are the enemies of each other.

A distinct pattern of violence, which began with Zari Jan's entry into the marriage, can be seen in this polygamous situation. Neither Arif, Maha Jan nor Zari Jan wanted the marriage to happen, but both Arif and Maha Jan felt compelled to find a second wife as they had not been able to have children themselves. Zari Jan's sole role in the family and the purpose of her marriage to Arif is as a child-bearer. When Zari Jan fails to fall pregnant, the frustrations Arif feels at being in this situation are heightened – leading to Arif's violence toward both of his wives. Zari Jan's function as child-bearer is confirmed in two further ways: first, Arif admits to loving Maha Jan more than Zari Jan; and second, the children in the family are perceived to be not only the children of Arif and Zari Jan but also those of Maha Jan. Indeed, Maha Jan refers to the children as her own and reports that they love her more than Zari Jan.

8.2 Reasons for polygamy – "protecting" a widow through marriage

One of the most common reasons found for men to have more than one wife was because they

had been obliged to marry the widow of a male family member. In almost all of these examples, the women had lost their husbands as a result of war – either directly or indirectly. There was a particularly high number of war widows in Bamyan Province. Similarly to the case of taking another wife for reasons of infertility, marrying a widowed woman in the family is seen as an unavoidable necessity for both the man and woman involved, as the case study below illustrates. The quotations in Box 7 make clear that it is considered shameful across the four provinces studied for a widow to marry outside her husband's family, and for many widows there is little choice in this as they are likely to lose custody of their children if they do not marry again within their in-laws' family.

The case of Mehri's marriage to her brother-in-law Riaz (whose family from urban Nangarhar, family map 11, was introduced in Section 4) shows that men are sometimes left little choice but to marry a widowed sister-in-law and that, as with the situations featured in Section 5, this "forcing" of men into marriages can lead to future violence in the family. It also demonstrates that the circumstances in which a polygamous marriage takes place can affect the future relationships within the family, not only between the man and his wives but also between the wives. Neither of the women was happy to enter into a polygamous marriage when Mehri married Riaz, but all concerned felt that they had little choice in the matter.

Mehri, now in her mid to late 30s, was first married when she was a teenager to Jalil. A year later she gave birth to her first child, a daughter, and three years later she had a son. Shortly after, Jalil, who was in the army, was killed. She says that her marriage to Jalil was happy. After her husband was killed, Mehri was a widow for three years until her father insisted that one of her brothers-in-law marry her. It was decided that her brother-in-law Riaz would marry her. He was very reluctant to enter into the marriage but felt compelled to do so, as he explains:

I was very sad because I didn't want to marry my brother's wife – she was my sister-in-law and I said, "How can I marry my sister-in-law?"

My mind couldn't accept that my sister-in-law would be my wife. On the other hand, we can't tell a widow to leave the house, and we do not allow our widows to marry another person. I was obligated to marry her because of our culture.

Riaz's displeasure at having to marry Mehri was compounded because he was already engaged to Sharifa, his cousin, whom he did want to marry. Likewise, Sharifa was devastated at the news that her future husband would be married to someone else before marrying her, as she describes:

I cried a lot and my condition was very bad because I hadn't expected him to marry his brother's wife. All the time I was thinking, "What will my future with my children be like?", because it is very difficult to live with another woman. I should say that a woman can give anything and share everything with another woman, but she cannot share her husband. I thought about killing myself.

Sharifa's father and brothers were also upset and there were many arguments between the two families. Sharifa's family wanted to break the engagement, but Sharifa persuaded them not to, saying:

He is my first and last husband and I am Afghan; it is a shame for me to break my engagement.

Shortly after Mehri's marriage to Riaz, the Najibullah regime collapsed and the family fled from the ensuing conflict to Pakistan, where they stayed until 2002. Four years after marrying Mehri, it was decided that the wedding of Riaz with Sharifa would take place.

Riaz and Sharifa have now been married for about 11 years. Riaz and both his wives live in a large compound that they share with his brother and mother. Mehri has a separate room for herself, her daughter from her first marriage and the seven children she has had with Riaz. Riaz and Sharifa live in another room in the compound with their five children. Riaz's mother and one of his brothers with his wife and son, as well as Mehri's son from her first husband, also live in the same compound, but have their own living area. Like many of the families in this area of Jalalabad, they are very

poor. Riaz works at night as a guard and also does daily wage labour work when it is available. The one brother who lives in the same compound is in the army. Mehri's eldest son works as a tailor's apprentice, and Mehri makes some irregular income from making quilts.

Riaz claims that he tries to give both of his wives equal amounts of money, but despite this Mehri says that Riaz has told her that Sharifa is his real wife and he only married Mehri because he had to. As Mehri described her marriage to Riaz, she showed the research team a photograph of her first husband and said that all her problems began when he died and that they would not end until she dies.

The relationship between Sharifa and Mehri is fraught: despite living in the same compound, they do not even speak to each other. Sharifa believes that Mehri killed her first child, a son, when he was three months old. She tells the story of how one day she had left her son alone in her room while she went to wash dishes. When she returned to the room, blood was coming out of his ears and nose. The family took the baby to the doctor, who told them that someone had killed the baby by pushing on his stomach and neck. Sharifa reports that Mehri admitted to killing her son and that she is not regretful about it and claims she did it because Sharifa had delivered a son before her. Sharifa also explains that this is why Riaz treats Mehri badly, describing one of the times when Riaz beat Mehri and how it made her feel:

On that day my husband had an argument with [Mehri], saying "Why did you do it? My son was small and you killed him! You might be the enemy of my wife, but my son didn't say any bad words to you." He became angry with her; he took a big stick and he started beating her in the room. He beat her on the legs and shoulders, then my mother-in-law stopped him. I am very kind, because when my husband beat her I was in my room and I could hear her crying, and I became very sad because she is a mother and all of her children were crying a lot. I decided to go and stop him, but my mother-in-law was already there.

For reasons of confidentiality, it was not possible for the research team to corroborate Sharifa's story about the death of her son with other members of the family; in any case, the rivalry and jealousy between the two women is clearly so strong that either one has murdered the other's child or the other is willing to accuse the first of murdering a child. Riaz does not talk about the problems between his wives; however, he admits to hitting them if they do not accept his advice or if they try to tell him what to do.

It is clear that neither Riaz, Mehri nor Sharifa was happy to enter in to this polygamous marriage but felt compelled to do so by prevailing cultural norms. They all knew from the outset that Riaz's marriage to Mehri would precipitate a problematic family situation. Unlike the example of Maha Jan and Zari Jan, Mehri and Sharifa are not a source of support for each other, even though at times Sharifa feels pity for Mehri.

In other cases, men are happier to marry their sisters-in-law than Riaz was; for example, Nowrooz Bay (family map 3), whose family was introduced in Section 4, was happy to marry his sister-in-law, Masooda, as it meant that there would be more children in the home (his current wife had given birth to only one son). Masooda says he married her so that he could claim her and her children's inheritance from their father. While Masooda did not want to marry him, she felt compelled to do so as she feared she would otherwise lose custody of her children to her husband's family.

A widow who marries her brother in-law and in doing so enters a polygamous marriage rarely acquires the same status as the woman who married the man as her first husband. In a small number of cases, it was also reported that the family members of the deceased man took out their grief and anger on his widow, as these two quotations illustrate:

I haven't beaten my second wife, but I beat my first wife, who was the wife of my brother who died and I then married her. When my brother died, I was injured and detained in Mazar by the Taliban. When I would come home I would remember my brother and beat her up.

— Middle-aged man, urban Bamyan

[My daughter-in-law] married him because she did not want to make her son an orphan again by leaving him. I said, "Let her go where she wants to go," but she accepted to marry [my other son], just for the sake of her own son... Whenever I see her I feel sorrow for my dead son and I miss him, but she wouldn't leave her son...when I see this woman day and night, it refreshes the sorrow of my late son.

— Older woman, urban Bamyan

Not all widows who marry their brothers-in-law are marrying a man who already has a wife, and not all of these men take another wife after marrying their sister-in-law. Furthermore, a small but significant number of widows interviewed during the course of the research were able to avoid marrying another member of their husband's family; for example, Latifa, from urban Bamyan, after being widowed twice while extremely poor and still quite young, has managed to build a home next to her parents' house and live there with three of her children, while another three children live at a nearby orphanage.⁴⁹

8.3 Reasons for polygamy — men marrying again for a different type of marriage

A small number of examples were found in which a man married a second wife simply because he or his family were not "satisfied with the first wife." The first example comes from rural Nangarhar. Naeem has two wives and also lives with his father and his children (family map 12).⁵⁰ He describes himself as having a medium income in the village, owning 9 *jerib* of land and working as a schoolteacher. He is also a mullah. He explains his reasons for taking a second wife:

Firstly, when my wife would go to her father's house and spend some nights there, with my mother being too old cook, we would go hungry as there was no bread. Secondly, my wife made arguments with my mother and my mother made arguments with her. My first wife did not want to live with my mother. So then my mother told me to get married again, and I agreed.

Part of Naeem's motivation for his second marriage is to have another woman available for domestic work. Unlike in Arif and Maha Jan's example, Naeem's second marriage was not discussed with his first wife and she only found out about it when he brought his second wife to the house. Like Riaz and Mehri's example, there is a great deal of conflict between Naeem's two wives. The problems between these two women had become so bad that Naeem had recently built a wall through the middle of his compound so that the two women could have separate households. He says he now divides his time equally between the two households.

From the same family, Shafiq (Naeem's *nasaka* sister's son), who was introduced in Section 5, is reported to now want to marry again, but this has less to do with his dissatisfaction with his first wife than his desire to have a "romantic" or "love" marriage in which he chooses his bride rather than his parents:

Now he tells his mother, "I am in love with another girl and I want to marry her. Why did you marry me off when I was still a teenager?"

Shafiq's mother is fiercely against this idea; first, she is fond of his first wife and does not want to see her hurt; and second, she has seen all the difficulties that her *nasaka* brother, Naeem, has in his family because of Naeem having two wives.

A similar example was found in rural Kabul: Farzana and Loqman were married when they were teenagers, and they are paternal cousins and grew up in the same compound (family map 19). Farzana's *nasaka* mother is Loqman's mother — now Farzana's mother-in-law. Both Farzana and Loqman highlighted the forced nature of their marriage. They have five children aged between 6 and 16 years; they also live with Loqman's mother, Loqman's and

⁴⁹ These examples are explored further in Smith, *Challenging Myths*.

⁵⁰ It should be noted that Naeem did not live in one of the core households of the case study families, so his wives were not interviewed and their perspective is missing from the narrative. Other women in the extended family did, however, discuss his marriages.

Farzana's half-brother and Loqman's two widowed sisters-in-law and three children. They are not a poor family; they have sufficient land to grow crops for themselves, lease to sharecroppers and sell produce in Kabul city. Loqman also has a car, which he uses to taxi people between the village and Kabul city. He is educated to 6th grade and his brother Assadullah has completed high school. None of the women in the family have been to school and the girl children only go to school when they are young and can attend the village school.

Farzana spoke to the research team about how she felt when her father decided to marry her to her paternal cousin:

I didn't want to marry Loqman because he is my cousin and we had lived in the same compound since we were born. I didn't want to marry someone I had grown up with.

A further reason that Farzana did not want to marry Loqman was that her *nasaka* mother, who is Loqman's mother, would then become her mother-in-law. This woman treated Farzana very badly as a child, and Farzana had hoped that marriage would have provided her an escape from this abuse. Farzana explained how bad her marriage is and that her husband has proposed to another woman:

*My relationship with my husband is not good, because both of us did not want to marry each other. Even two years ago, before my husband was sick, he wanted to marry a second wife and he sent his sisters-in-law for *khoostgari* [proposal]... When my husband came I started fighting with him and asked him why he wanted to marry again. My husband said, "Because our marriage was not my choice; second, I was very young and I did not enjoy my wedding and now married life; and third, I did not have a proper wedding party because of the war, so I want to marry and enjoy these things."*

Farzana explained how she retaliated by telling her husband that she is in the same position as him:

I said, "I also did not enjoy it, same as you. I was also newly married when we were in

basement.⁵¹ And also I did not see any wedding party or engagement party, any gifts or any other things from side [of the family]. Since I do not complain about these things, why do you want to marry again?"

These examples show how in some cases the dissatisfaction of a man or his family with a current wife can lead to the desire to marry another woman. In the first example, Naeem and his mother are not happy with his first marriage because of the arguments his first wife has with her mother-in-law and also because when she visits her father there is no one in the house to do the domestic work. The other two examples are closely linked to the consequences of forcing boys into marriages against their will, as explored in Section 5. In both of these examples, the men feel that they were forced into their first marriages and have not had the opportunity to have a marriage which they see as ideal, so they both have the desire to marry again and experience this.

8.4 Reasons for polygamy – a first marriage being delayed

While a first marriage being delayed was a less common reason for the situation of polygamy, it is worth discussing, as it highlights again how those involved feel compelled to comply with cultural norms and expected gender behaviour and to live in family structures that they knew would be likely to be problematic.

Abdul Sabor (family map 14), first introduced in Section 5, lives in Nangarhar city with his elderly mother, two wives, Rahima and Sabrina, seven daughters and four sons. He is disabled from injuries he suffered during the Soviet-mujahiddin war, and the family is relatively poor. The compound in which they live has only two rooms – one for each wife and her children. When Abdul Sabor was a young boy, his father took a second wife and basically left Abdul Sabor and his mother, sisters and brothers to fend for themselves; his brothers and he all went out to work at a young age. Despite this, he

⁵¹ Farzana and Loqman had to hide in a basement from a bombing raid on their wedding night, and Loqman's sister was killed.

managed to get some schooling. Abdul Sabor relates all the problems he suffered as a child to his father having had a second wife, and he deeply regrets that he has ended up in the same situation, as he explains:

I cannot forget the bad situation that went on in our family. I swore I would not marry two women, because I saw all the fighting at home and how bad it is to marry two women, but unfortunately I am faced with this problem... I didn't want to have two wives. It is difficult for me to provide food for them, and you know that I am very poor and disabled.

Sabrina, Abdul Sabor's second wife, is the daughter of his mother's brother. When they were both very young, it had been agreed that Sabrina would marry Abdul Sabor in exchange for his sister marrying her brother. The marriage of Abdul Sabor's sister happened immediately. However, since Abdul Sabor and Sabrina were younger, their marriage was delayed. By the time they were ready to marry, the Soviet-mujahiddin war had begun and Sabrina's family migrated to Pakistan. Sabrina's father accused Abdul Sabor and his family of being *kafeer* (non-Muslim – implying he was a communist) because Abdul Sabor was in the police force. For this reason, they would not let the marriage take place for 14 years, despite repeated requests by Abdul Sabor's mother. Abdul Sabor did not want to marry anyone else and remained single until his mother's sister proposed that he marry her daughter, Rahima, in exchange for Abdul Sabor's sister marrying her son. Abdul Sabor's family agreed to the marriages and Rahima became Abdul Sabor's first wife. Meanwhile, Sabrina had refused to marry anyone else but Abdul Sabor, who she was still engaged to.

When the Soviets left Afghanistan, Sabrina's family returned to Afghanistan and her father decided that she should now marry Abdul Sabor. Abdul Sabor was then very reluctant to marry Sabrina as he already had a wife. He was put under heavy pressure to agree to the marriage by elders from Sabrina's community along with her brothers. Rahima, his first wife, was extremely upset but also felt there was little choice for them, as Abdul Sabor described:

Rahima didn't say anything, but she was indeed sad and I told her that I have to marry Sabrina. Then my wife told me to marry her.

Despite Abdul Sabor and his wives all living together for at least 16 years and the fact that all members of the family reported that Abdul Sabor treated his wives equally, there remains a great deal of conflict in the family – not only conflict between the two wives but also violence from Sabor toward both of them, particularly if they argue with each other or are violent with the children.⁵² The extent to which Sabrina and Rahima regret being in a polygamous marriage is best illustrated through their hopes for their own daughters' marriages:

I promised my Allah that even if it cost me my own life, I would never marry my daughter as an ambagh. I know poverty is from Allah's side, so I will marry my daughter to a poor person but certainly not to a man who has another wife. If such things happened, I would rather kill my daughter before I married her to such a person.

– Rahima

If someone has one [wife], it is better. If someone has two [wives], then the lives of three people are destroyed... When I got married to my husband, Rahima cried a lot, as did I... I want to marry [my daughters] with single men; he shouldn't have another wife.

– Sabrina

All those involved in this marriage did not want to be in a polygamous marriage, but they had felt compelled to enter into the situation. Sabrina felt she had to marry the first man she was engaged to, despite the fact that he had already married someone else. Abdul Sabor also felt that when the elders and Sabrina's brothers came to persuade him, he was not able to refuse the woman with whom he had been earlier engaged. Rahima was unable to protest that second marriage taking place and accepted that Sabor, too, had little choice but to go ahead with it.

⁵² Abdul Sabor's attitude toward corporal punishment and violence toward children is explored in detail in Smith, *Love, Fear and Discipline*.

8.5 Relationships between *ambagh*

The worst consequences described by respondents of having more than one wife, and the most common reason found for disapproval of the practice, is conflict between women married to the same man. In most of the examples found during the research, including those examined above, there was overt conflict, rivalry and violence between *ambagh*. Despite this, some examples were found where women married to the same man had proved to be a source of support for each other, such as the case of Maha Jan and Zari Jan. Other women had, over time, found ways to live in cooperatively, often when there is a significant age difference between them.

Gull Jan, Dowlat Bibi and Marghlara, the first, second and third wives of Haji Khoram respectively (family map 20), are aged 60, 48 and 40 years. The reason that Haji Khoram married his second wife was because Gull Jan had not given birth to sons. His second wife, Dowlat Bibi, did not produce any children, so he married Marghlara, who has had four sons and four daughters. While there are some problems between the wives, they report that in general they all get on well, which can in part be attributed to the differences in their ages. Gull Jan was prepared to take on the role of the older woman in the house, living separately and no longer having a sexual relationship with her husband. Dowlat Bibi, while not having borne her own children and having experienced some difficulties when Marghlara first came to the family, now enjoys Marghlara's children and supports her in bringing them up. That the family is relatively economically comfortable – they own a large shop, land and animals, which allows each wife to have her own room in the compound – has certainly been an enabling factor in their cooperative relationship. Gull Jan explains how things have been organised to minimise conflict in the family:

He used to stay two nights with me and two nights with Dowlat Bibi, but since he married Marghlara I gave up my two nights to her so Marghlara could get pregnant. First, when Marghlara married him, we had a few problems, but now we have a good relationship with each

other, especially as everyone gets older... When Marghlara was married, Dowlat Bibi started to have arguments in the house; for example, she used to say that I am older than Marghlara and why is Haji Sahib giving her money and that she doesn't respect us elder wives in the house.

Like the case of Maha Jan protecting Zari Jan from their husband's violence, Aziza's marriage as a fifth wife to a Balochi man (who everyone simply calls Baloch) provides another example of *ambagh* supporting and protecting each other from their husband's violence (family map 17). Aziza's marriage was introduced in Section 7 as an example of a young woman being forced into marriage for bride price. Baloch is a particularly sadistic man who attempts to turn his wives against each other as well as being very violent to all of them. On one occasion he found them smoking a chillum and as punishment made them all stand on one leg for an hour. When Aziza put her leg down, he slapped her across the face. He has thrown knives at her and repeatedly strapped her with a belt. However, despite the desperate situation in the household and Baloch's efforts to set the wives against one another, Aziza said that the other wives (except the first wife) would always try to help and support her. She has a particularly good relationship with one of her *ambagh*; this woman had helped Aziza access birth control, and between them they ensured that Baloch never found out about this, as Aziza explains:

She knew about the thing I was doing. I mean about the prevention of pregnancy. She was also doing the same. She didn't want to have a child from our husband either. She was clever and she helped me to get contraception and we both used tablets. She was literate and her family married her by force when she was very young, just like me. [Our husband] sent us to see the doctor. When he went out of the room, we said to the doctor, "Please, for God's sake, don't tell him anything. We are not happy with him and we don't want to have any children from him." She promised to help us. After my husband came back in, the doctor said to him, "One of your wives is young, and that's why she can't get pregnant now. Your other wife is unable to get pregnant; she won't get pregnant at all."

Aziza has now left her husband, and with the support of her mother and paternal uncles, she is attempting to divorce him. However, she lives in constant fear that he will find her.

8.6 Conclusion

This section has shown that for many men, marrying a second, third or fourth wife is often not a situation that they enter into willingly. Likewise, the women they marry are almost always unwilling to enter into a polygamous marriage but have little choice in the matter. Polygamous marriage is something that, under particular circumstances, individuals feel compelled to enter into in order to conform to social norms and expectations of men's and women's behaviour in the family. Polygamous marriage was generally viewed by the respondents in this study, both men and women, as an undesirable family structure in which to live. While polygamous marriage is viewed as acceptable in Islam, the condition that all wives must be treated equally was stressed during focus group discussion and individual interviews, while the difficulty that this presents was also acknowledged.

Using case studies, examples have been provided which illustrate the circumstances in which men and women enter into polygamous marriages. The first two reasons, infertility and the marriage of widows to men from their husband's families, are both commonly viewed as undesirable but unavoidable. Children are seen as essential for family survival primarily as they offer support to parents in old age, and it is considered shameful for widows to marry outside of their marital family. Furthermore, the marriage of a widow within the family is seen as the means by which children from the husband who has died should be supported. Widows are compelled to enter into these marriages or risk losing custody of their children to their husband's family. The third reason for polygamous marriage, men's dissatisfaction with their current wife or wives, is generally viewed as less acceptable. Links were identified between this reason for marrying a second wife and boys being forced into their first marriages, as explored in Section 5. The fourth reason identified for polygamous marriage is when

a first engagement is delayed and the man marries another woman, but he is still obliged to marry the first woman he was engaged to. While this was found to be far less common, it was discussed as it provides a further example of how compliance with expected behaviours for men and women can result in the practice of polygamy.

The primary reason that polygamous marriages are thought to be detrimental to family structures is the conflict they cause, which is recognised to have a harmful effect on the lives of not only the adults in the family but also the children. While most of the case study data confirmed that the fact that there often conflict, at times quite severe, between *ambagh*, there are exceptions to this in which *ambagh* support each another, particularly in resisting the husband's violence. Where this was the case, certain factors such as the involvement of a first wife in the decision for a man to marry again, existing relationships between the women concerned, differences in age between the wives and wealth status (allowing the wives to live separately) were identified as potentially lessening the levels of conflict produced by the polygamous marriage and encouraging support between *ambagh*.

9. Conclusions and Recommendations

This report has explored the decision-making processes in relation to marriages and marriage practices within Afghan families. The findings of the research fall into six key areas:

- diversity in the processes used for making decisions about marriages and how marriages are practised;
- degrees of choice and force when decisions about marriages are made;
- the effect of compliance with cultural norms on marriages and marriage decisions;
- the divergence between personal desires and perceptions of cultural norms;
- the links between violence in the family and particular marriage practices; and
- awareness within the community about the negative consequences of exclusionary decision-making processes and particular marriage practices.

A significant degree of diversity was found in the ways in which decisions are made about marriages from family to family as well as from sibling to sibling within individual families. With so many factors affecting how decisions are made about marriages and what the outcomes of those decisions are, this is not surprising. Within the context of a particular family, it is not only gender and generational dynamics that affect who is included in the decision-making process but also individual experiences and characteristics. A range of factors that are external to the family were found to affect the decision-making process, such as the economic and political situation at the time. It was also noted that individuals from very similar demographic backgrounds can have quite different perspectives on the appropriate way to decide about marriages and conduct them. Given that the factors leading individuals and families to make decisions in particular ways or to choose particular marriage practices are so diverse, generalisations based on gross demographic characteristics such as residential location (rural or urban), education

or poverty levels cannot be made in relation to what causes people to make certain decisions about marriages in their families. Instead, a more nuanced and detailed understanding is necessary if the most detrimental aspects of how marriages are decided on and practised in Afghanistan are to be overcome.

The notions of force and choice featured prominently during the course of the research. It was argued in Section 4 that the way in which people enter into marriages operates along a range from choice to force: while some marriages fall at the extreme ends of this range, many others contain elements of both choice *and* force. Some children may agree to a marriage even if the timing is not agreeable to them rather than upset their parents, even in cases where parents have not exerted undue pressure. Other children may not be asked for or give consent, but their families find less overt ways of establishing whether their children are happy about the suggestion of a particular marriage partner. Age is a critical determining factor in an individual's ability to give free and informed consent to a marriage, so it is as important to consider at what age a marriage is agreed to or an engagement made as it is to focus on the actual age of marriage.

Social and cultural expectations lead people to feel forced into a marriage or to feel that their choice in the matter has been constrained. Section 8 examined how particular social or cultural expectations, as well as more practical concerns, can lead people to enter into marriages that they would otherwise have not chosen, such as a man entering a polygamous marriage in the hope of having children with a second or third wife when a first marriage has not produced children, a widow having to marry a brother-in-law to provide support for her children and to prevent them being taken from her by her marital family, and a man having to marry his sister-in-law or other female relative if they become widowed.

As the examples in Section 8 showed, compliance with cultural norms and expectations can result

in people entering marriages that they know may present difficulties for them in the future. However, it was determined that cultural norms and expectations of gendered behaviour are not rigid and do not go unquestioned: the personal desires of many individuals were found to be at odds with their interpretation of what the current cultural norms for arranging marriages are. Differing understandings were also found within the same communities as to what the prevailing cultural norms actually are. While on one hand this divergence between perceived cultural norms and personal desires may show that cultural norms are difficult to change, on the other hand it demonstrates that the practices adopted by individuals and communities are very much open to discussion and that there is a readiness for change – at least among some members of the communities. Particularly in relation to asking children their opinion on prospective marriage partners, there was evidence of a significant shift toward more inclusive decision-making having taken place in recent years.

The main reason for this divergence between cultural norms and personal desires is an awareness, perhaps growing, of the detrimental consequences of more exclusionary decision-making processes and certain marriage practices. Respondents also pointed to the un-Islamic nature of some of these practices and behaviours. This was highlighted specifically in Sections 5 and 7, which discussed individuals' opinions on including children in decisions about their marriages and the practices of exchange marriage and bride price. While there is that awareness, alternatives to the dominant practices or ways to break the cycle of paying and receiving of bride price were less common. Section 6 presented some of the further reasons that families may feel pressure to marry children in ways that contradict their aspirations for their children to married when they are older and with them having at least some say in who their marriage partner is.

Sections 4, 5, 7 and 8 examined the correlation between the way marriage decisions are made and the particular marriage practices used and subsequent violence in the family. A link between forcing boys into marriages and their tendency to be violent toward their wives was established,

as was the link between exchange marriages and a self-perpetuating cycle of violence and abuse toward the women who are exchange for each other. It should be noted that certain marriage practices, such as exchanging women, bride price and the marrying of widows within their in-laws' families, are themselves symptoms of prevailing gender norms and the low status of women in Afghan society. They are part of a system that serves to perpetuate the subordinate position of many women within families and in wider society. Despite the recognition of these relationships between marriage practices and violence in the family it is important to remember that the root causes for violence toward women can be found in the status given to girls and women in Afghan society.

Some existing stereotypes of Afghan men and women have been challenged, such as that of the "vulnerable Afghan widow": it was found that some of the most powerful women in families are in fact elderly widowed women. The stereotype of very young girls being forced into marriages perpetuates the myth that is only girls who are victims of forced marriage, when in fact many boys and men feel they are also forced into marriage, as do some older women. Furthermore, the commonly held view that it is primarily wealthy men who practise polygamy is debunked: men from different wealth groups can often feel compelled by social norms or family pressures to take more than one wife.

9.1 Key findings

Generation, gender, status and household structure all affect how much authority and influence an individual within the family can have over marriage decisions.

Decision-making processes leading to the agreement of a marriage and the specific marriage practice employed both affect the degree of violence that ensues between the couple and within the wider family.

Describing marriages as either "forced" or "not forced" is an oversimplification of the way in which

marriages are arranged. Elements of both force and choice are present in most decision-making processes about marriages.

In relation to the issue of force and choice – particularly informed choice – in marriage decisions, the age at which children’s marriages are agreed to or at which they are engaged is as important to consider as the age at which they are actually married.

Not only do women suffer due to prevailing gender norms, so too do men. While the suffering of wives who are the victims of their husband’s violence cannot be denied, men who are compelled to marry at an age or time that is not of their choosing or to a person they do not want to marry often also end up in bad marriages, depressed and frustrated. In working to prevent violence within marriages and in families, it is as important to focus on the levels of force and choice that men have had in their own marriage decisions as it is to consider that of women.

The majority of people in the communities where the research was conducted are aware of the negative consequences of excluding children from decisions about their marriages and of forcing girls or boys into marriages against their will. They are also generally cognisant of the detrimental consequences of exchange marriage, bride price and polygamy.

A significant proportion of people recognise that many of their cultural practices are contrary to Islamic principles, such as not including children – both boys and girls – in decisions about their marriages and certain manifestations of polygamy and bride price.

Individuals’ opinions and desires were often found to be in conflict with prevailing cultural norms and practices, with individuals, both women and men, seeing their personal opinions as more constructive, egalitarian and progressive than the cultural norms and practices of the communities in which they live.

The differences between individual personal opinions and cultural norms, and the awareness of communities of the detrimental consequences for both men and women of certain prevailing norms in relation to marriage, both point to a readiness for change in marriage practices in Afghanistan. Indeed, in the recent years of relative stability (at least in the provinces where this research was conducted), it was reported that some changes had begun to take place in the way marriages are decided on, drawing the process closer to the “choice” end of the spectrum than “force” and in this way reducing the potential for conflict and violence in families.

9.2 Ways forward

It is essential that reports, policies and programmes disaggregate women and recognise the vast amount of diversity in individual women’s status in the family. It is also important to deconstruct stereotypes of Afghan women, such as that of the poor vulnerable widow, and it should be recognised that Afghan men are also a highly heterogeneous group.

Awareness-raising campaigns should be careful not to tell people what they already know but instead raise awareness about alternative ways in which marriages can be decided on and practised, within the constraints faced by different families and individuals. Organisations working against detrimental marriage practices and violence in the family should collaborate with communities to find economically and practically acceptable ways of conducting marriages that reduce the risk of harm, both psychological and physical, to men and women.

As the quote from this older man living in urban Bamyan expresses, change will only come from the people and communities themselves:

Some customs and traditions jeopardise society. Forced marriage is against Islamic law and should be abolished. The people themselves should preach against this unlawful custom. The preaching of the Human Rights Commission and Karzai doesn’t affect them, and it is not enough.

This research found that people are open to discuss issues of how decisions about marriages are made and the detrimental consequences of certain marriage practices. Organisations working in this area should provide spaces for both men and women of different ages to discuss these issues. This would allow communities to devise their own ways in which marriages could be decided on and practised that are more in line with individuals' personal opinions and desires than the cultural norms and social expectations which have led many to feel compelled to agree to marriages they know will be problematic in the future.

Organisations working against violence toward women in the family, in all its myriad forms, should work at least as closely with men as they do women.

Equal attention should be drawn to the ages children are when their marriages are decided on as is paid to at the age at which children are actually married.

Finally, given that there is some evidence of constructive change having already begun in the communities where the research was conducted, which could be attributed to the recent relative stability, the most important way of allowing these changes to continue to take place will be the improvement of both political and economic security – giving communities the space to begin to enact their own desires for how they conduct marriages.

KEY FOR FAMILY MAPS

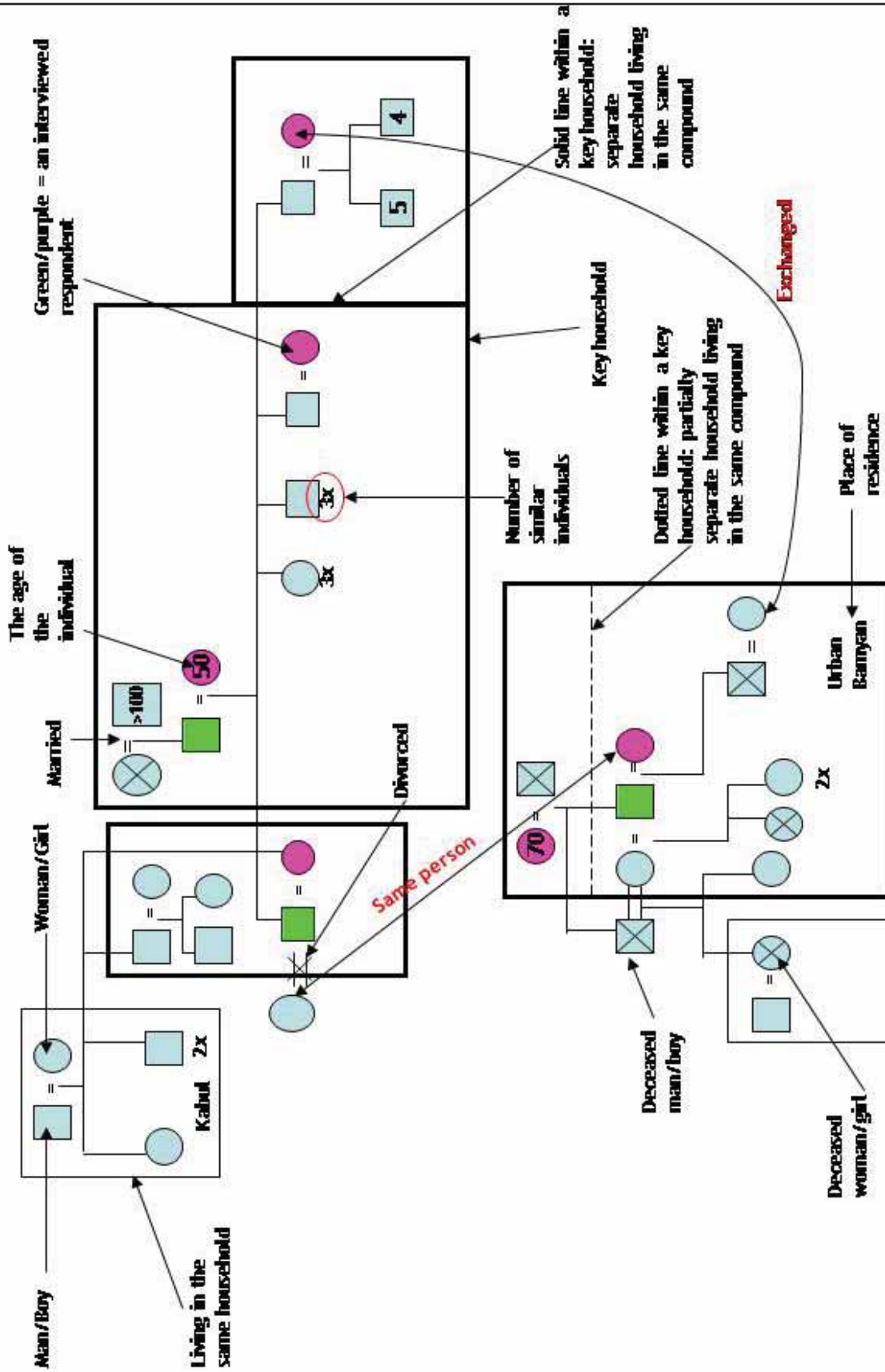

For some of the larger families, not all family members have been included in the family maps.

Map 1: Urban – Kabul Province – Bas Bibi Family

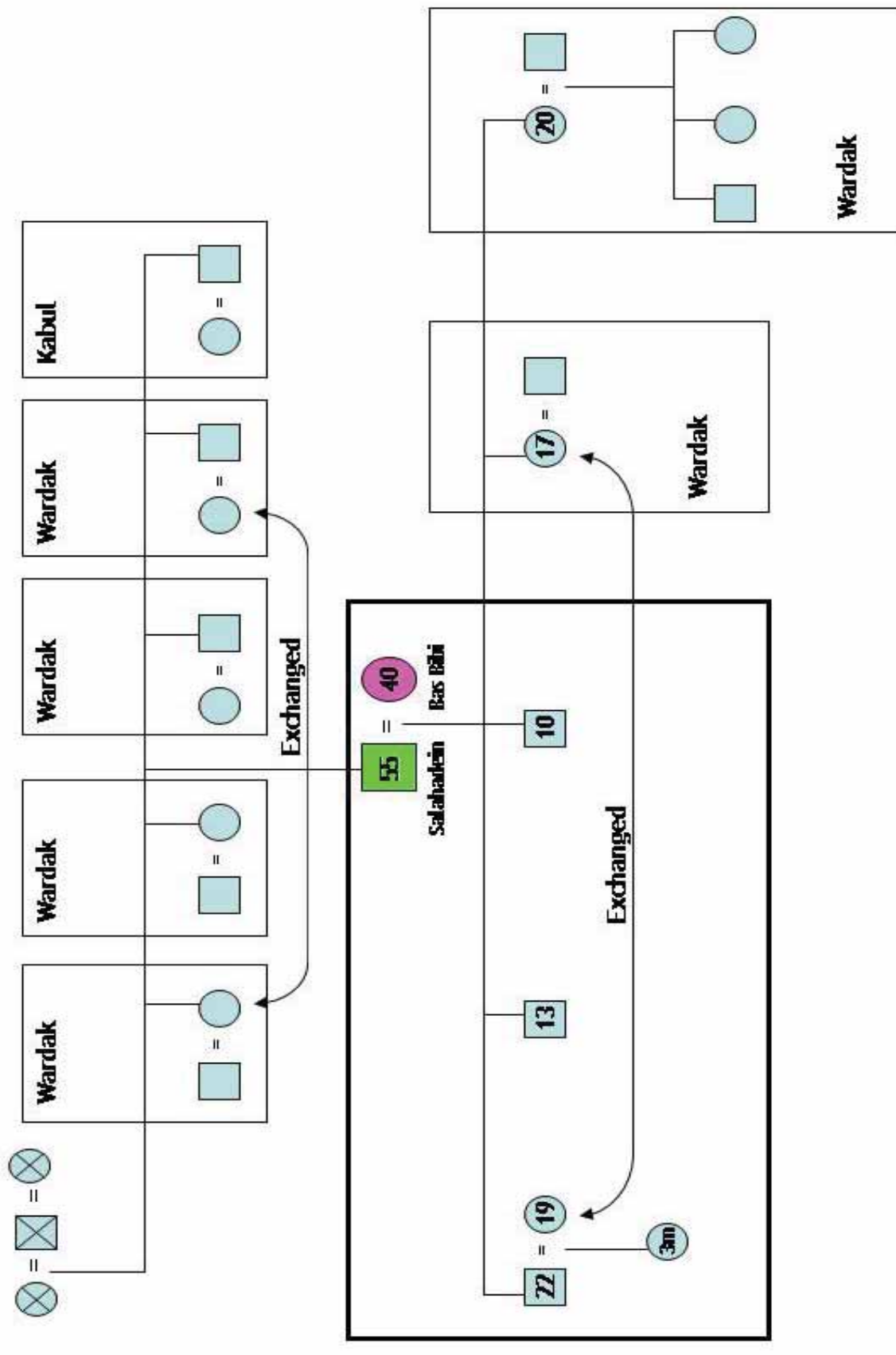

MAP 2: Urban – Bamiyan Province – Latifa Family

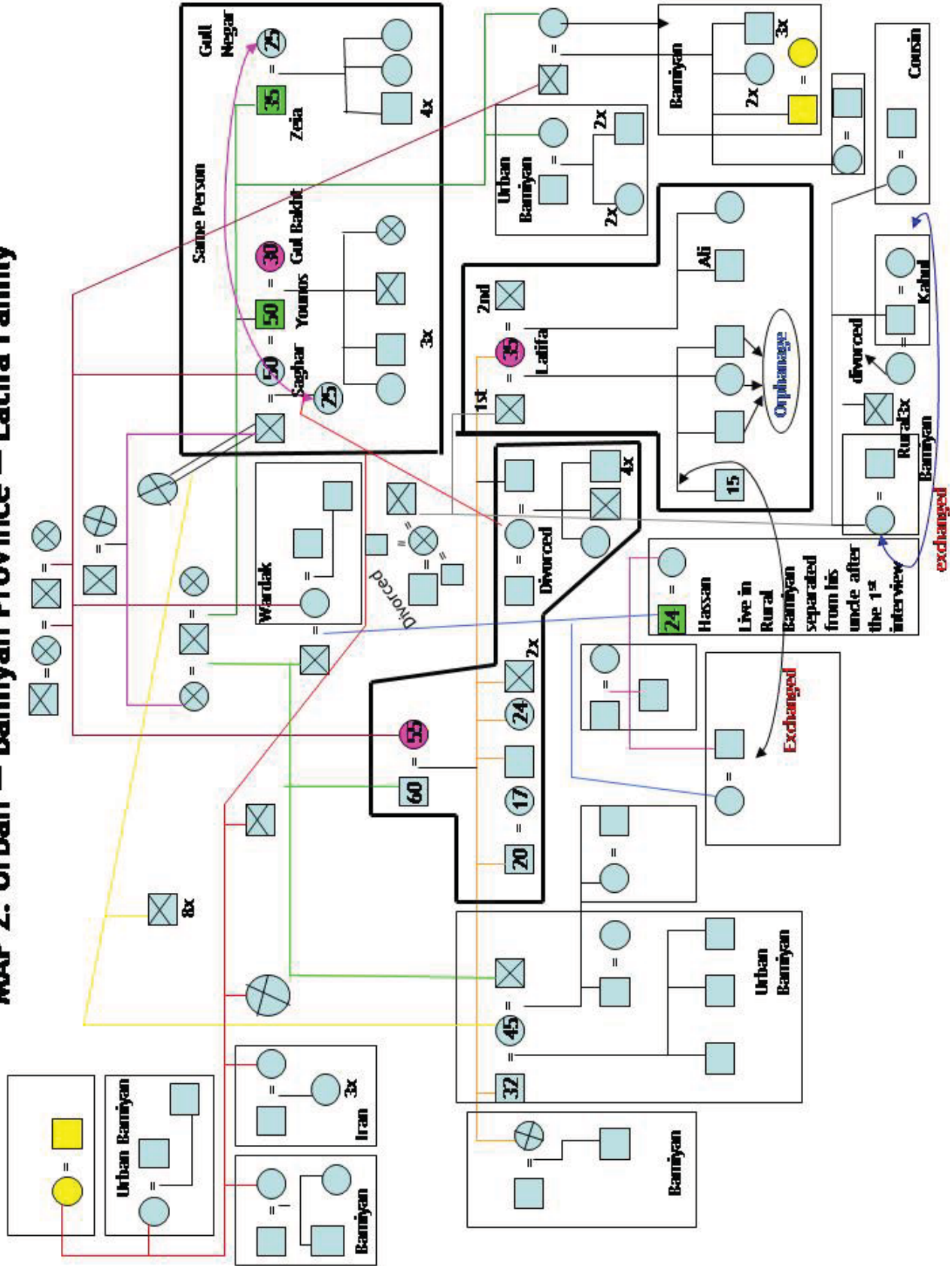

MAP 3: Urban – Herat Province – Nowrooz Bay Family

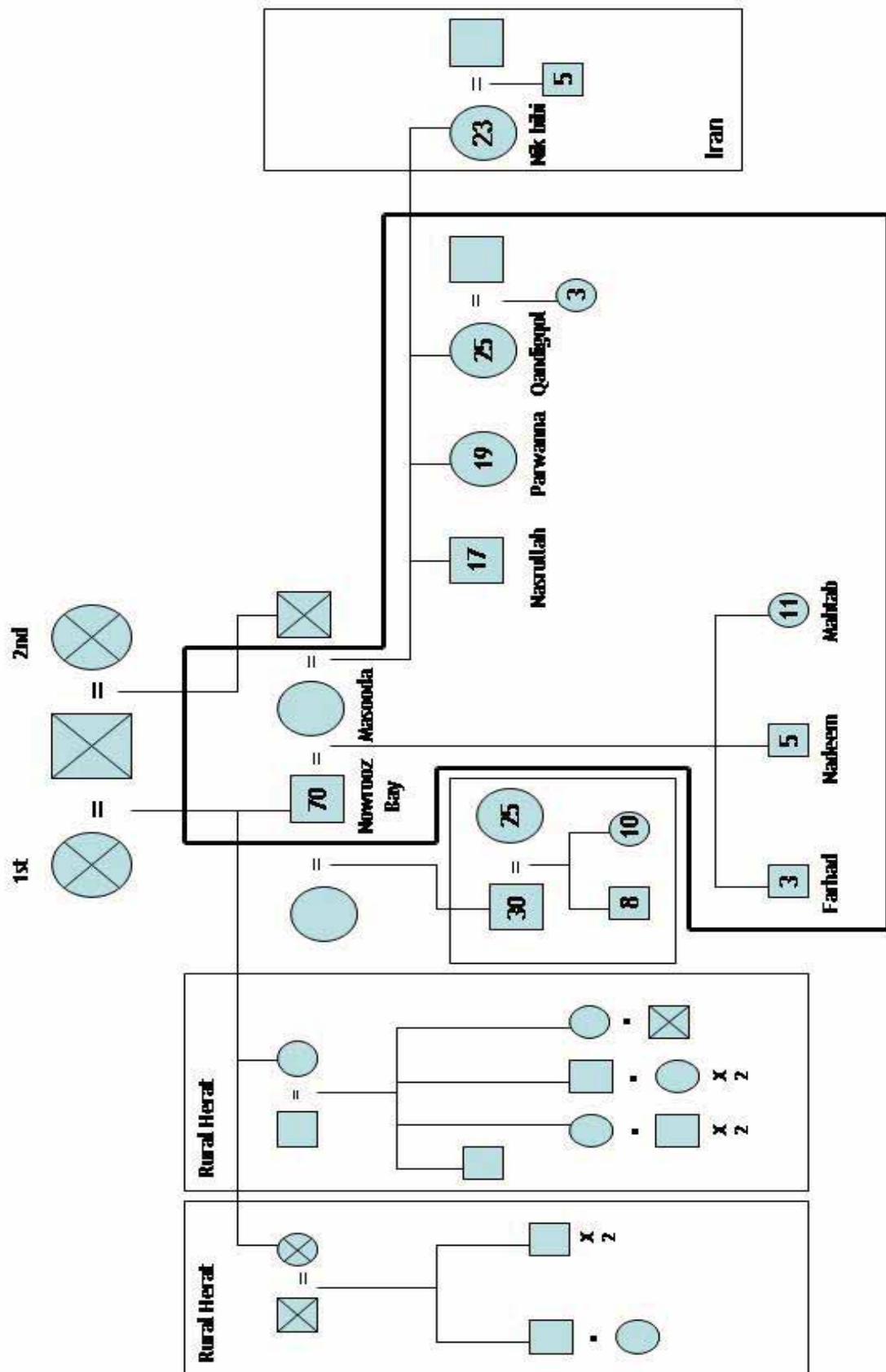

Map 4: Urban – Nangarhar Province – Shamsia Family

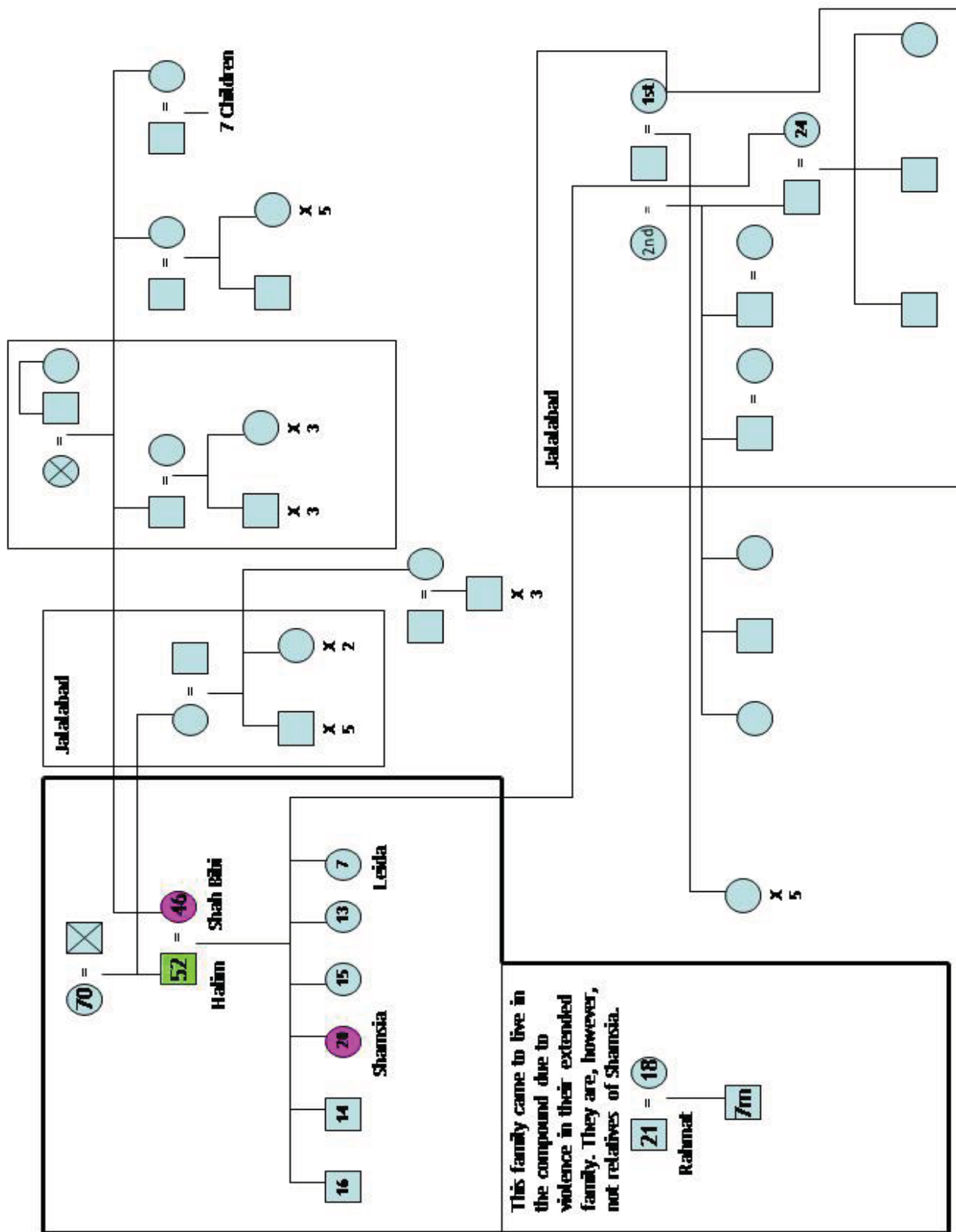

Map 5: Rural – Bamiyan Province – Momina Family

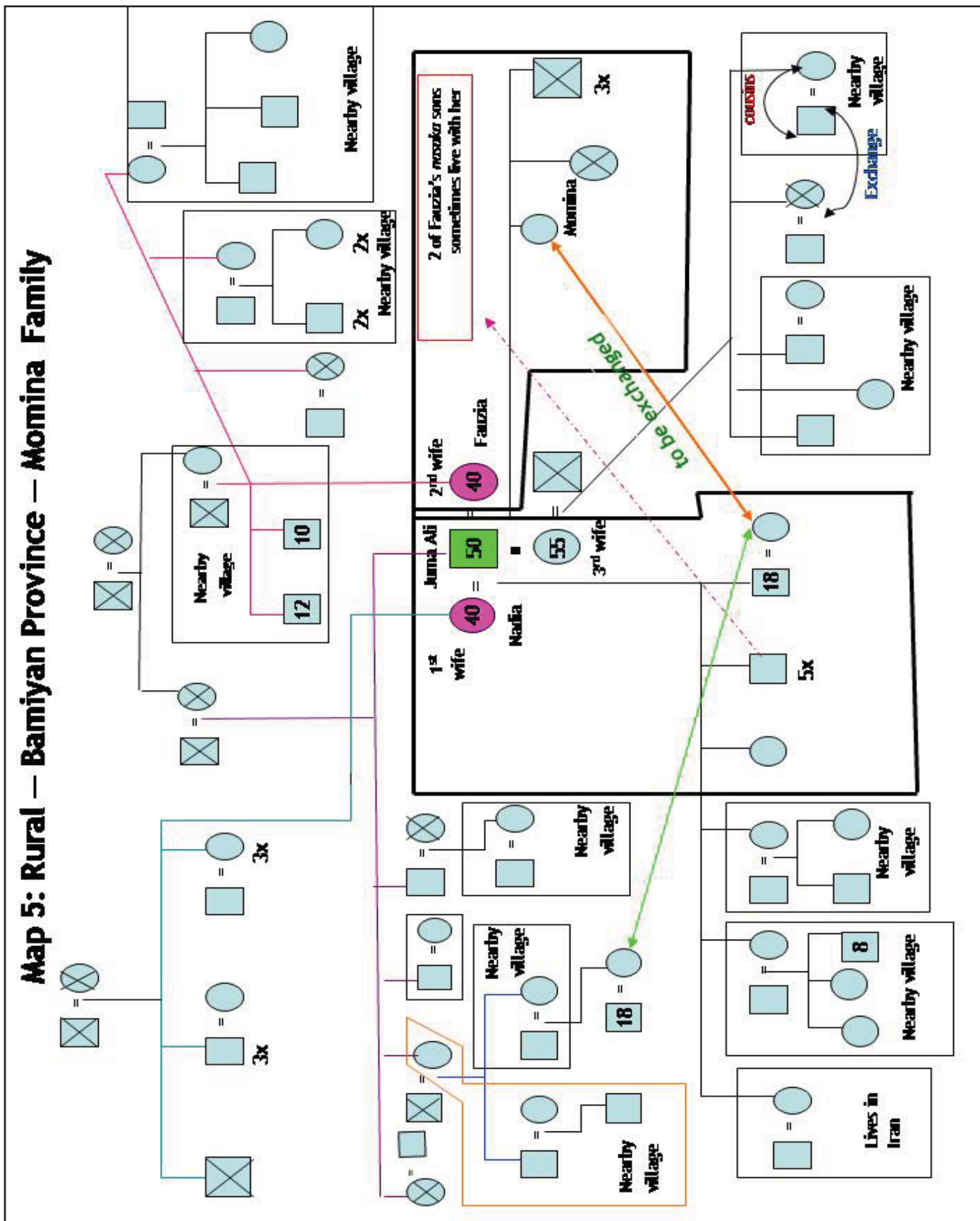

MAP 6: Urban - Herat Province - Suraya Family

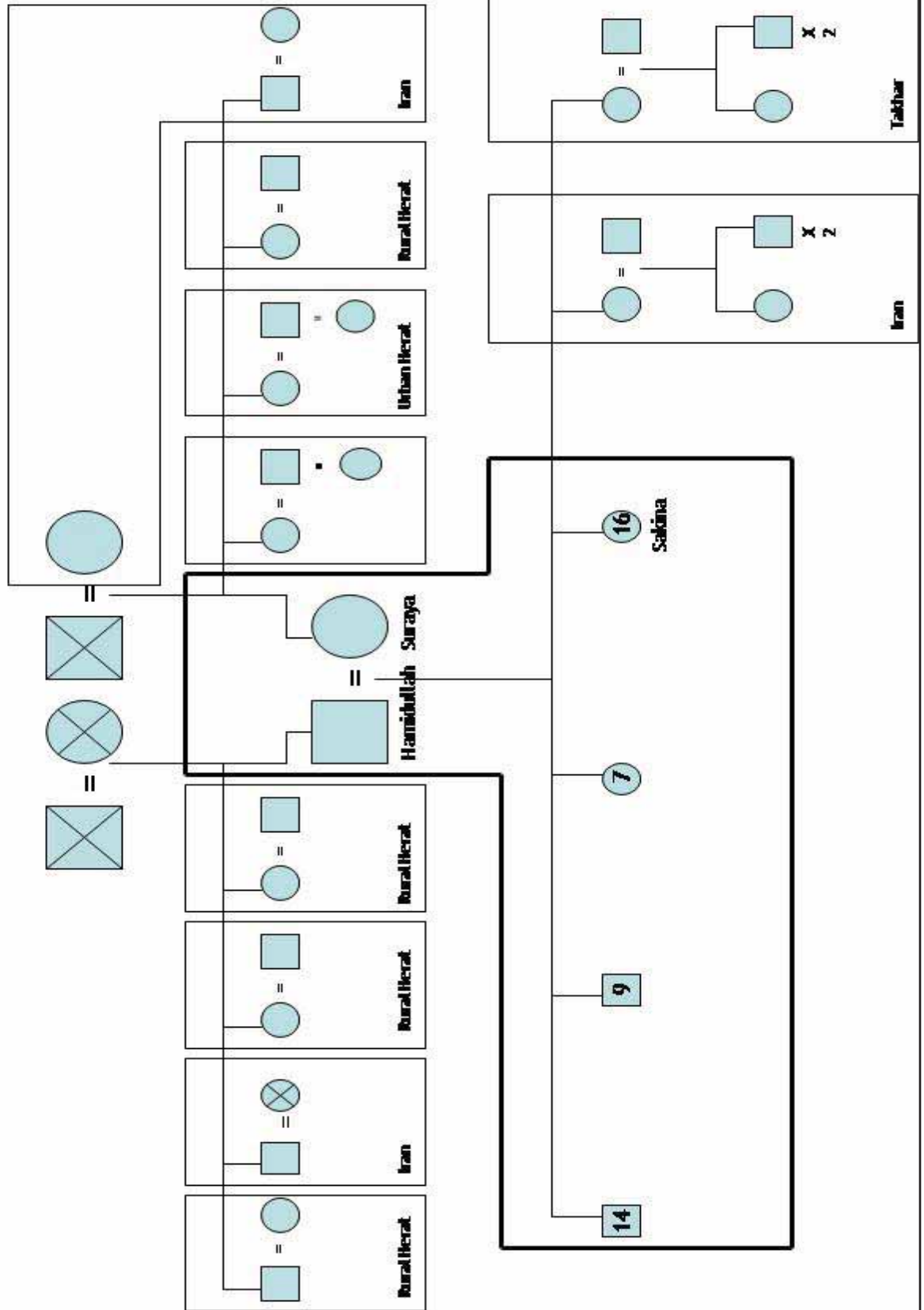

Map 7: Rural - Bamian Province - Haleem Family

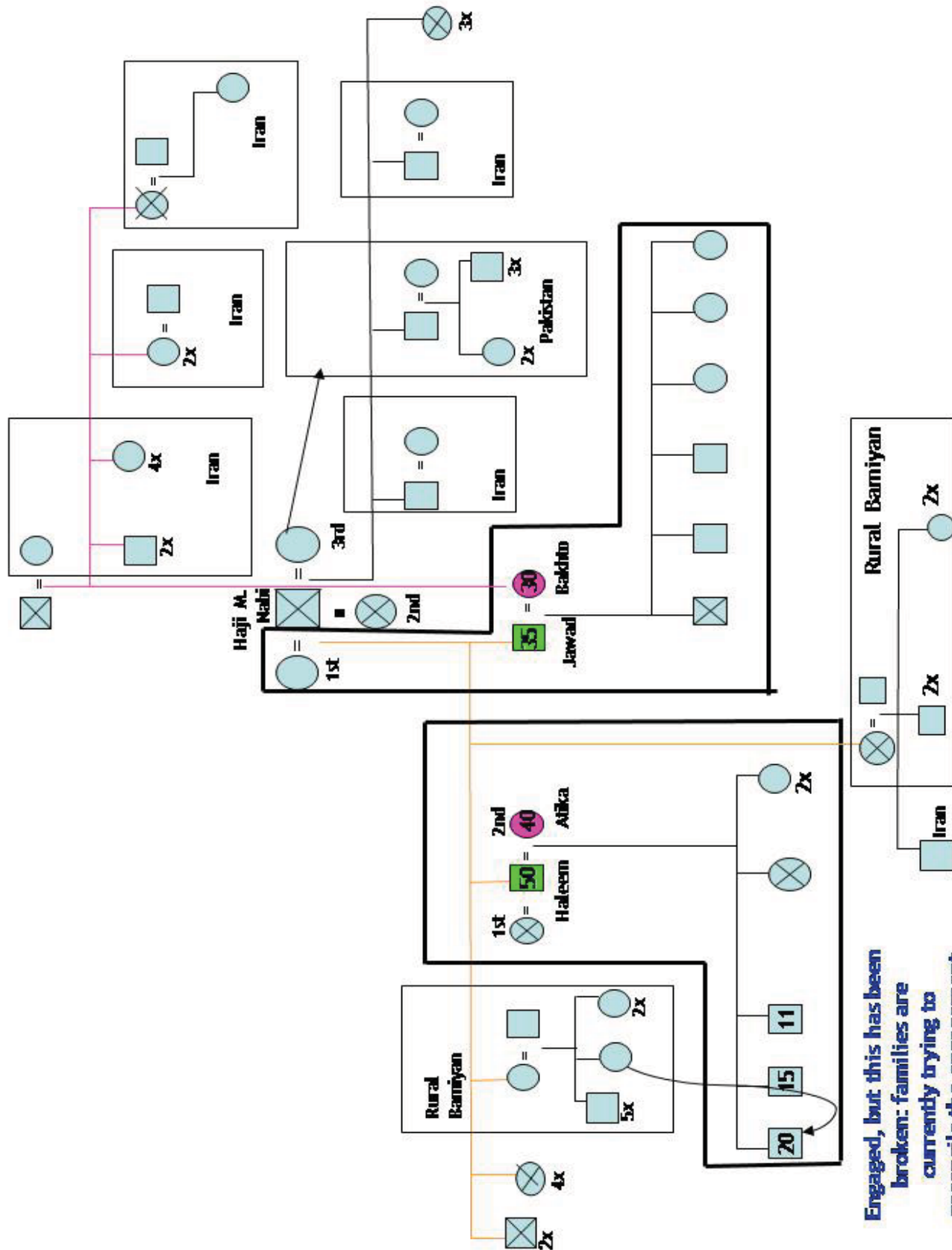

Engaged, but this has been broken: families are currently trying to reconcile the engagement

Map 8: Urban – Nangahar Province – Shereen Family

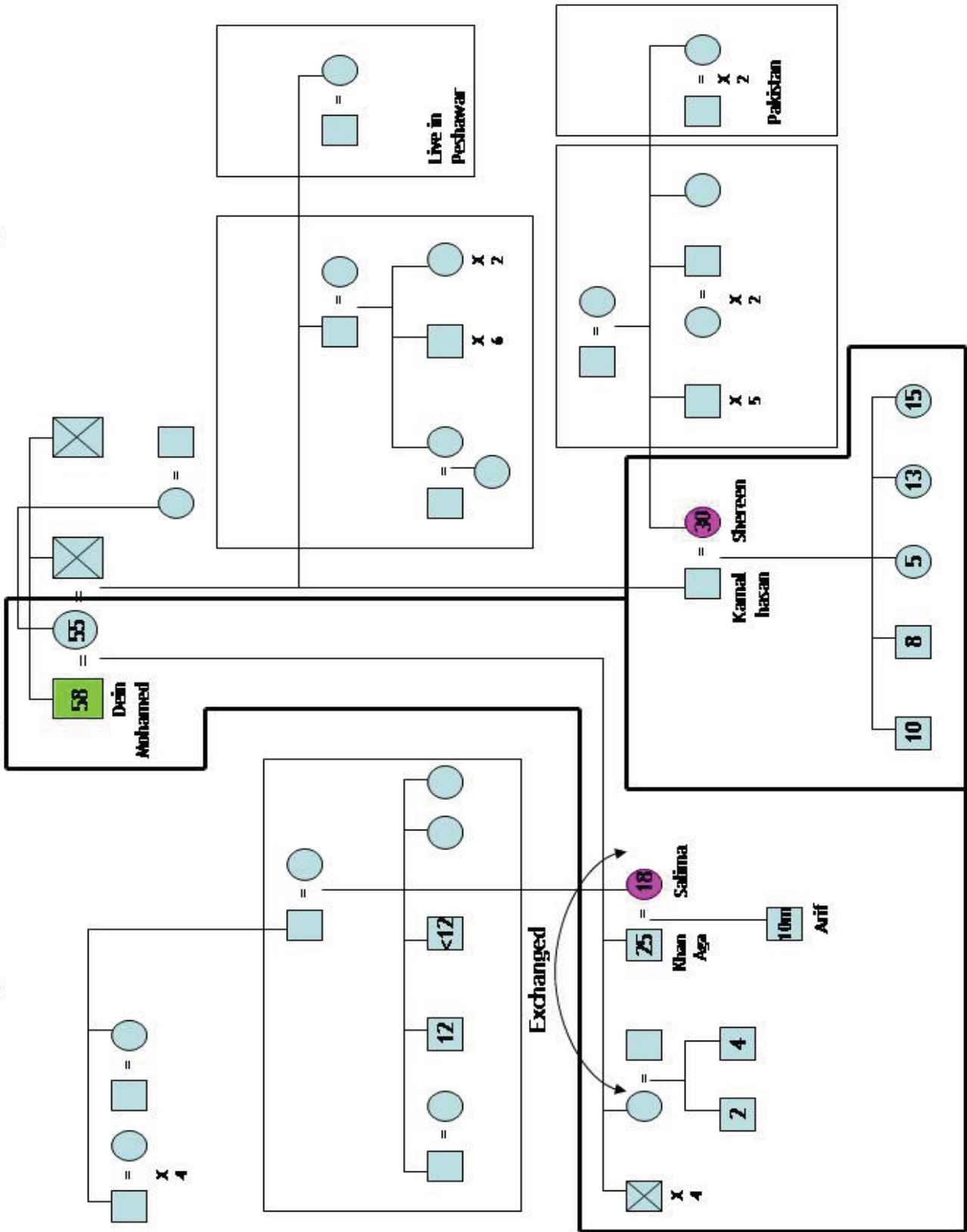

Map 9: Urban – Bamiyan Province – Zeba Family

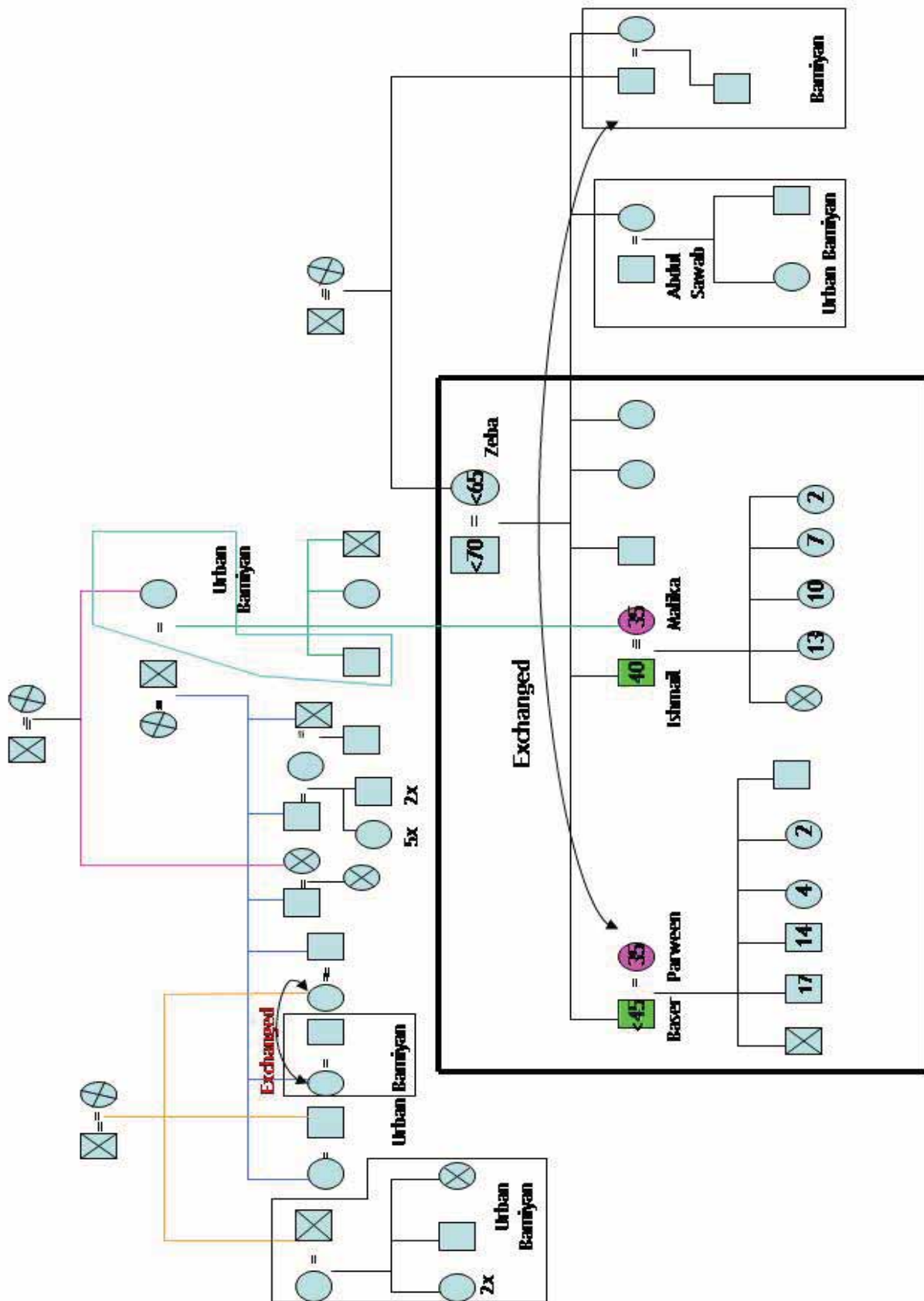

MAP 10: Urban – Nangarhar Province – Ghulam Ahmad Family

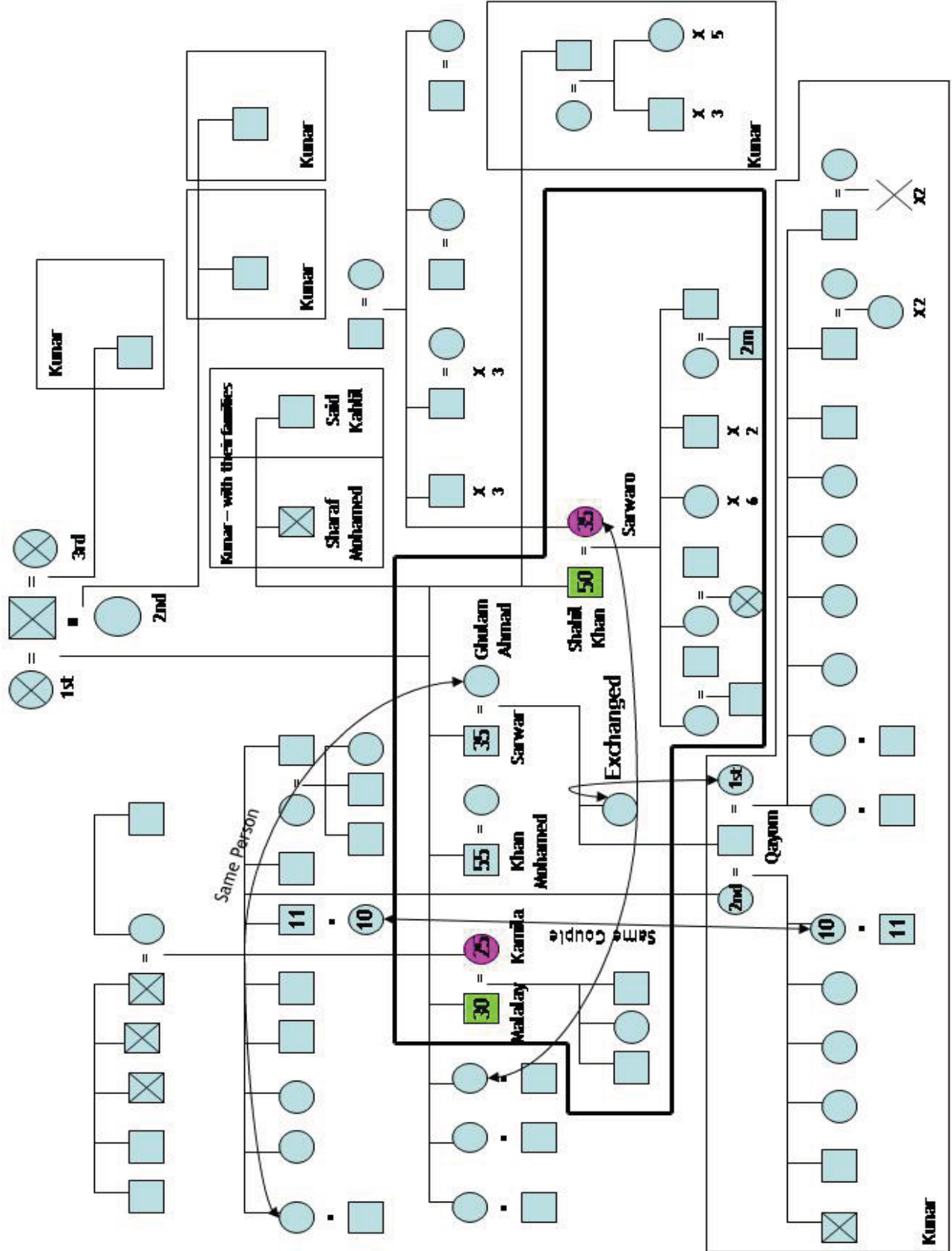

Map 11: Urban – Nangarhar Province – Riaz Family

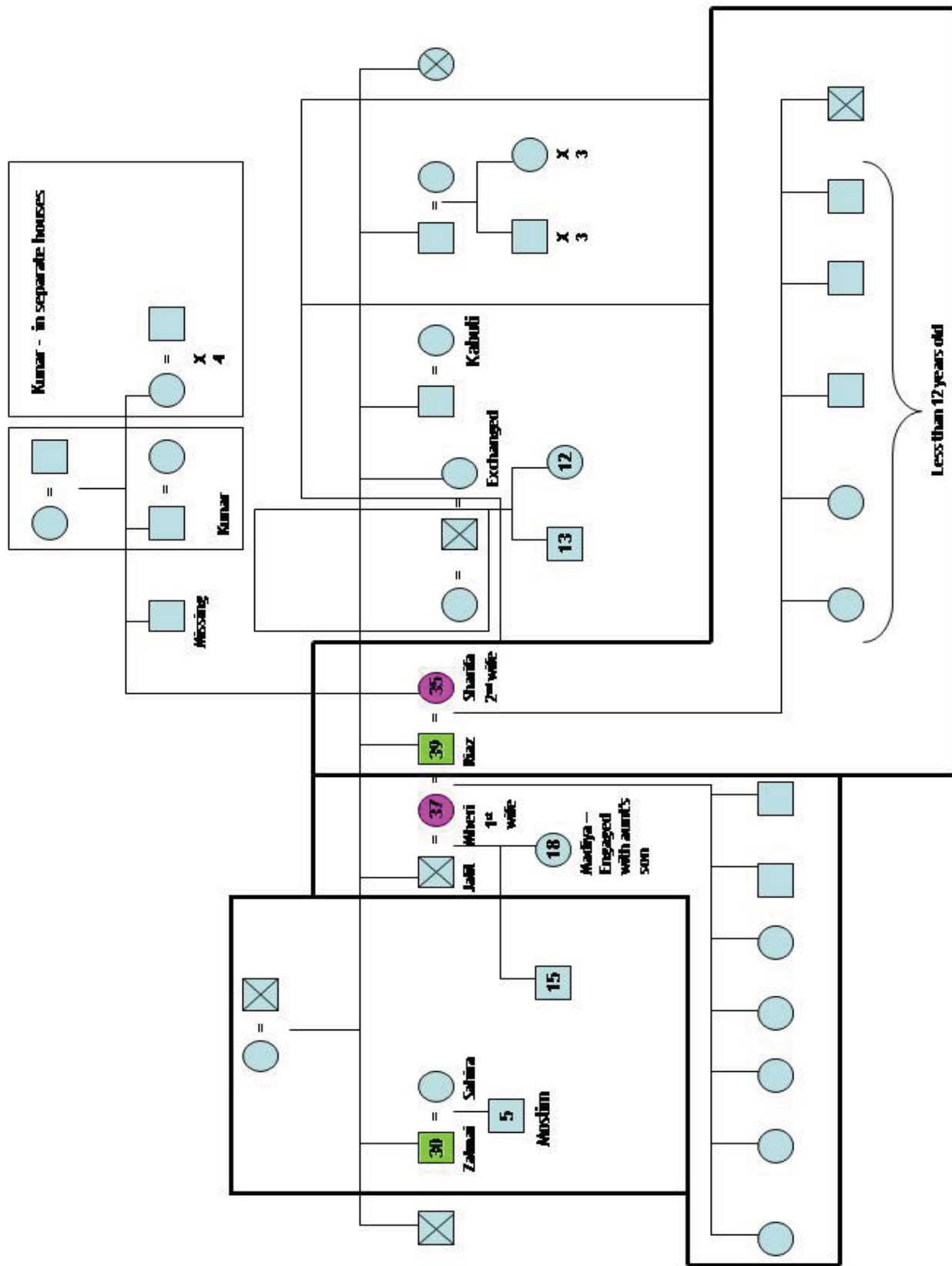

Map 12: Rural – Nangarhar province – Daya Family

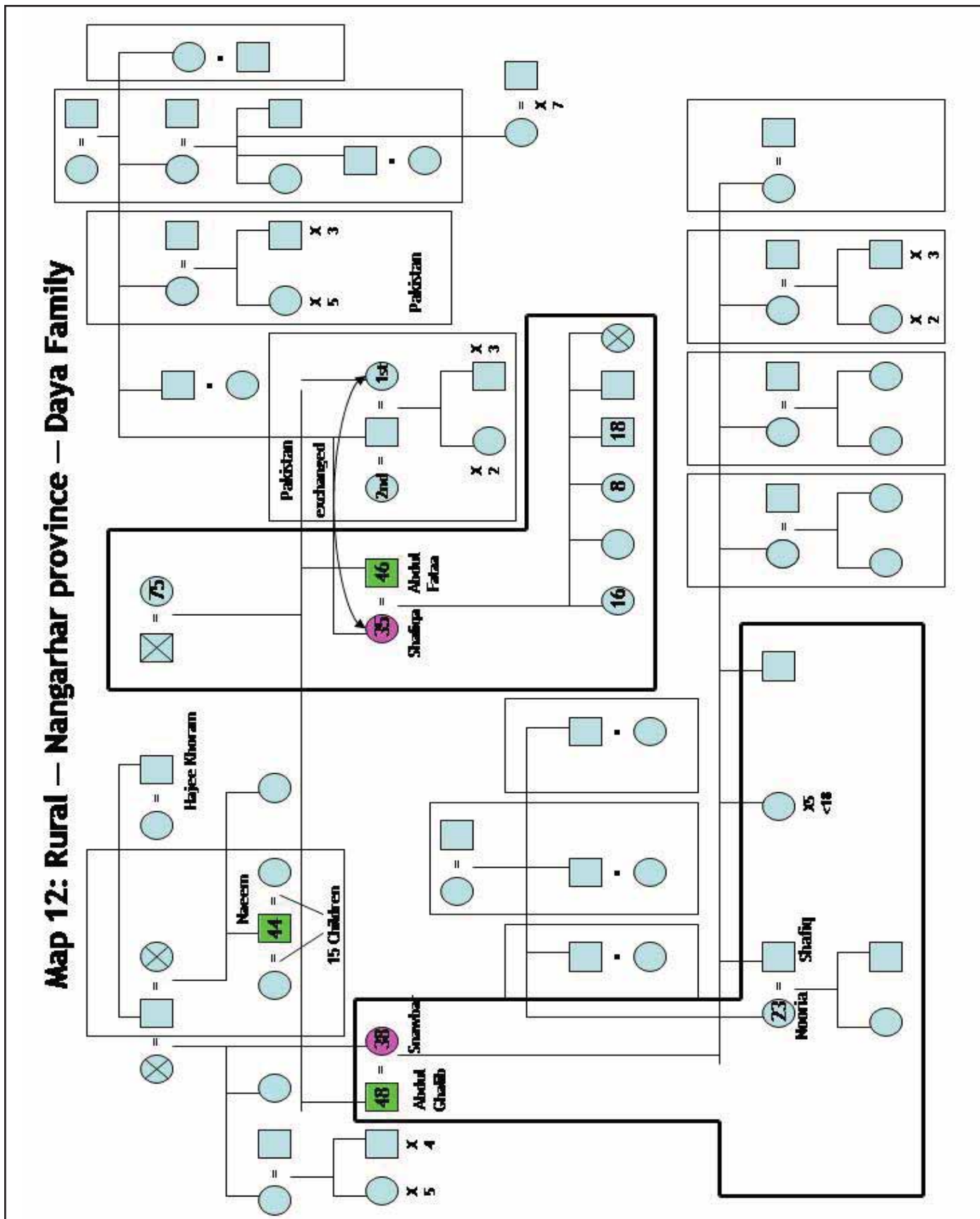

Map 13: Rural – Herat Province – Sheemagul Family

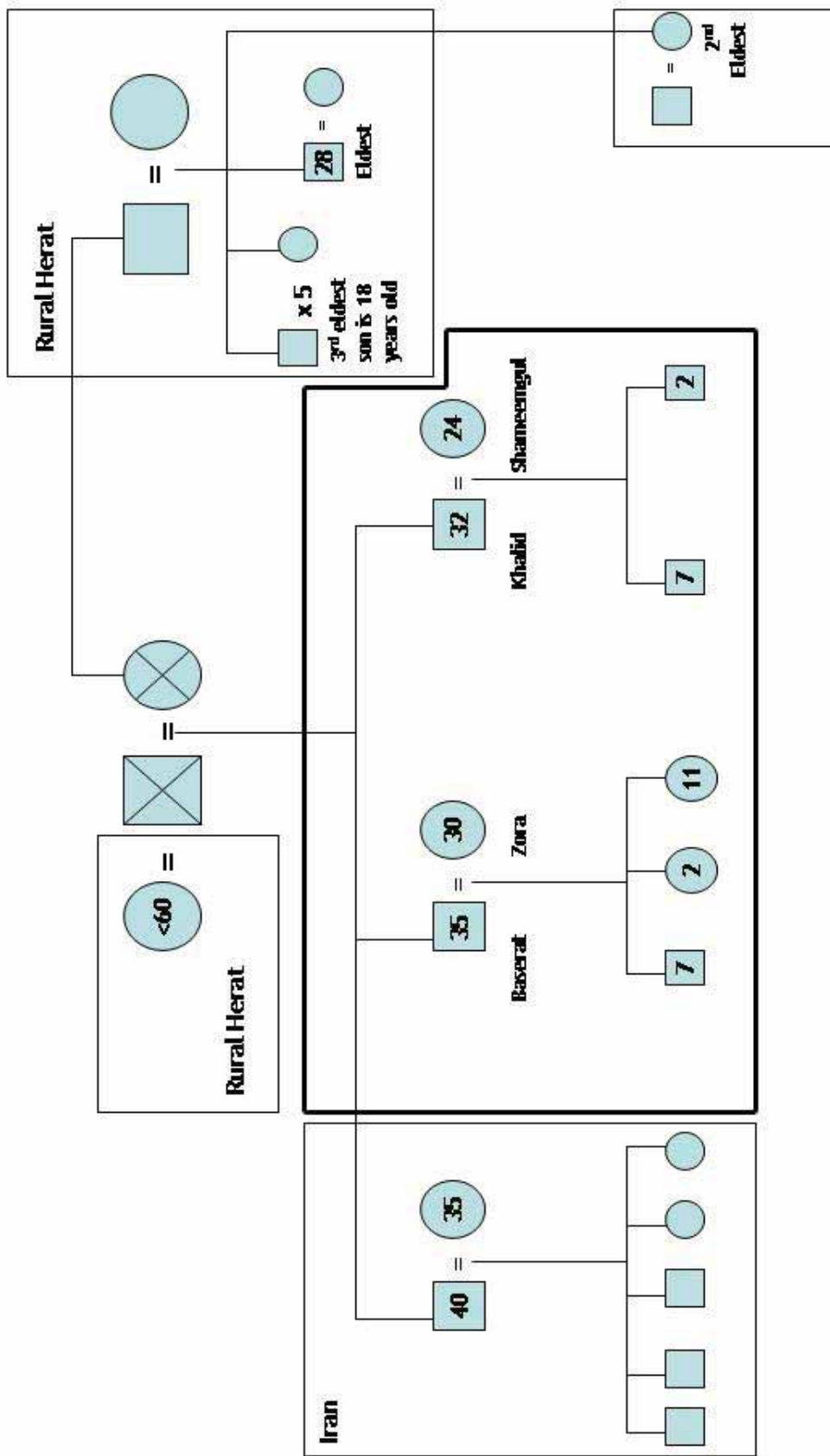

Map 14: Urban – Nangahar province – Abdul Sabor Family

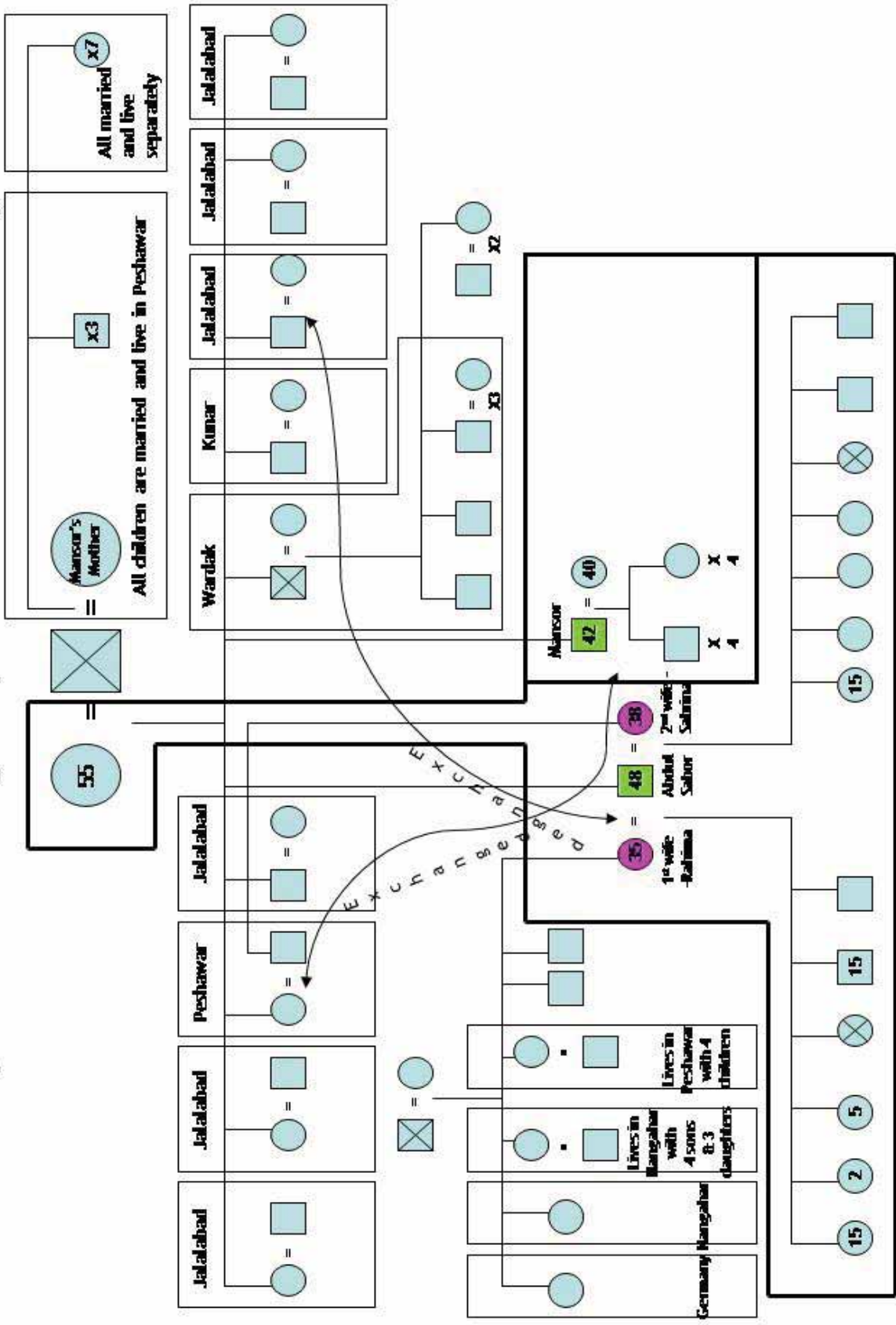

MAP 15: Urban – Kabul Province – Nabi Family

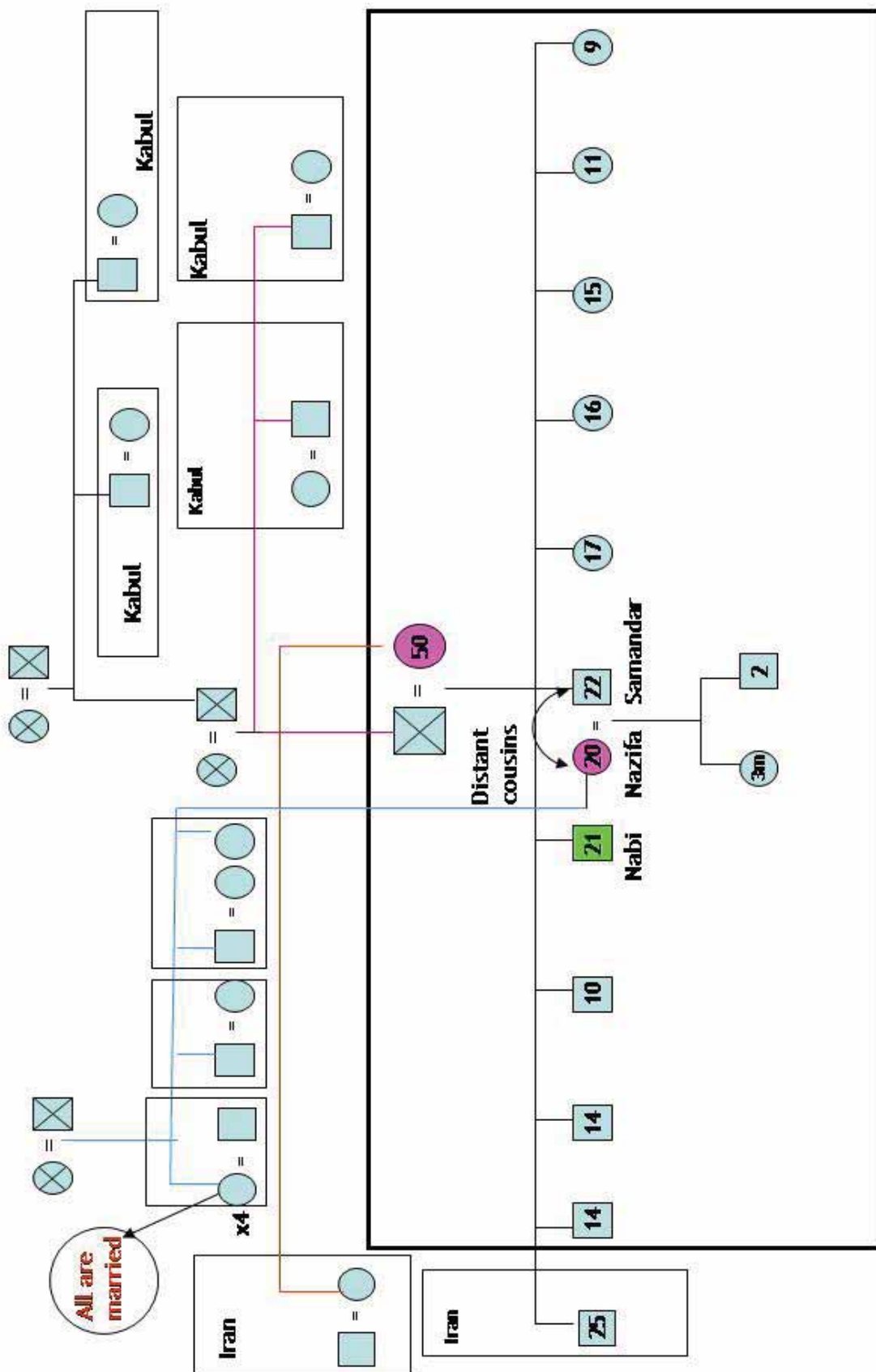

Map 16: Rural – Nangarhar Province – Naz Bibi Family

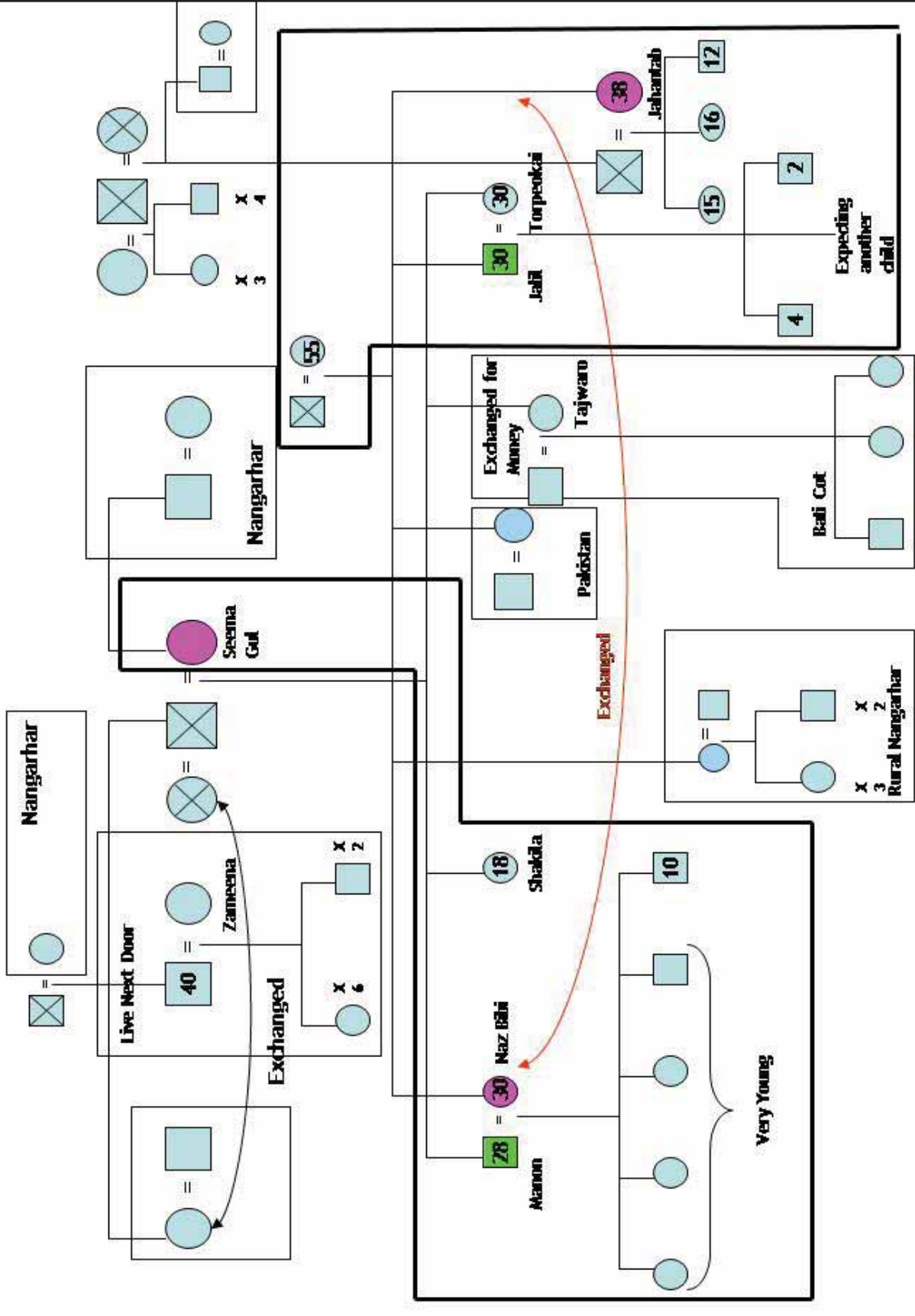

Map 17: Rural – Herat Province – Aziza Family

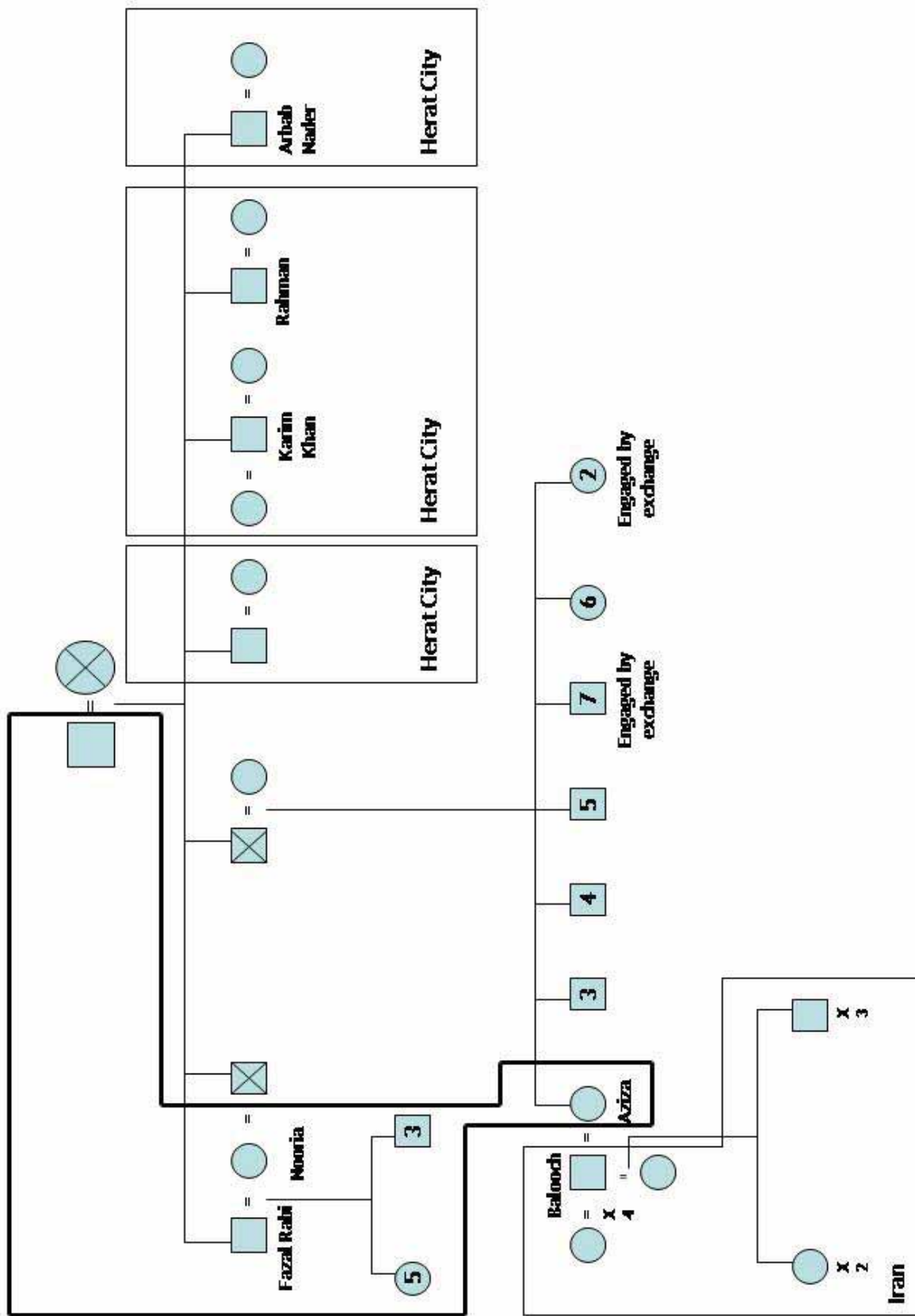

Map 18: Rural – Kabul Province – Maha Jan Family

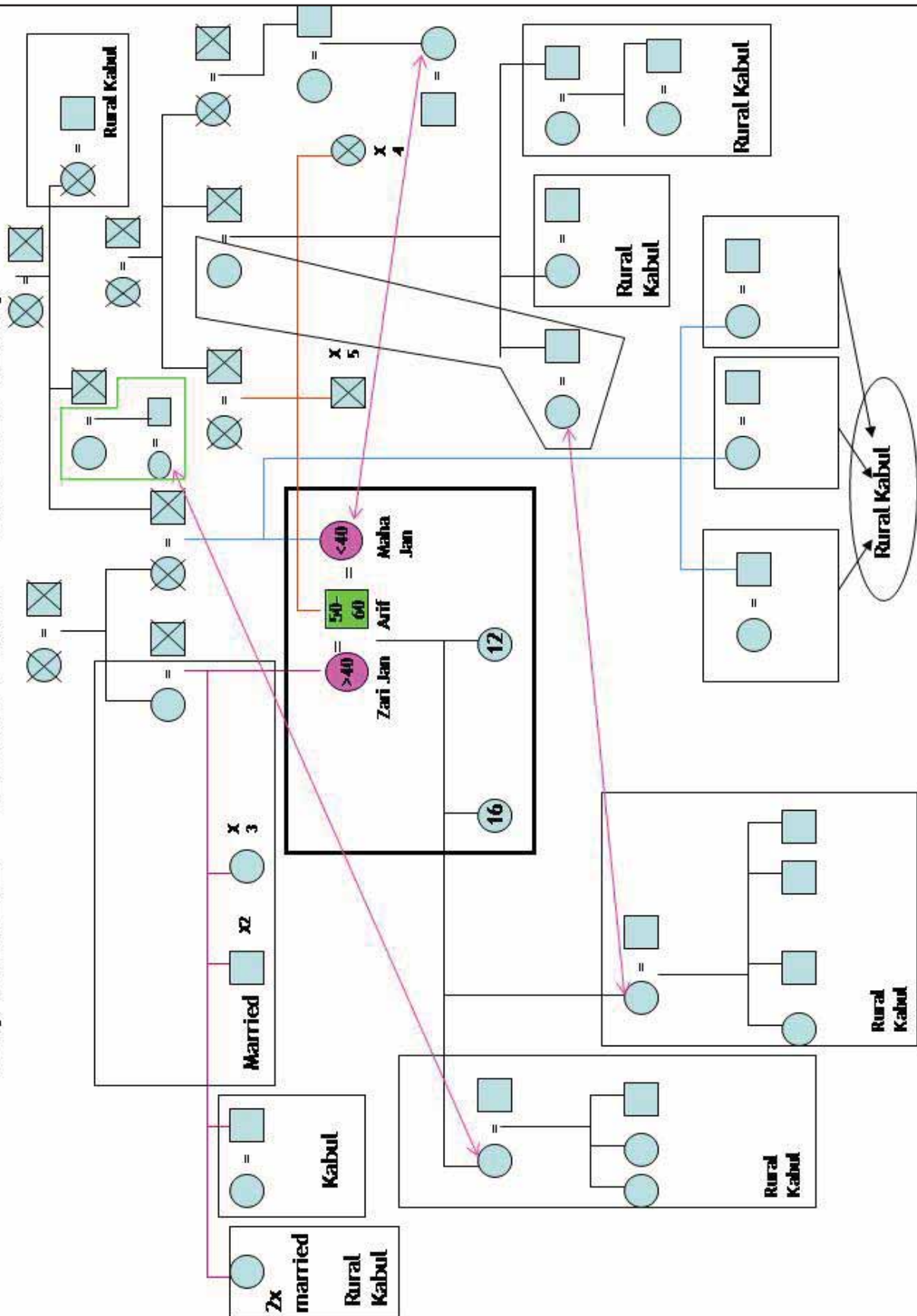

Map 19: Rural — Kabul Province — Logman Family

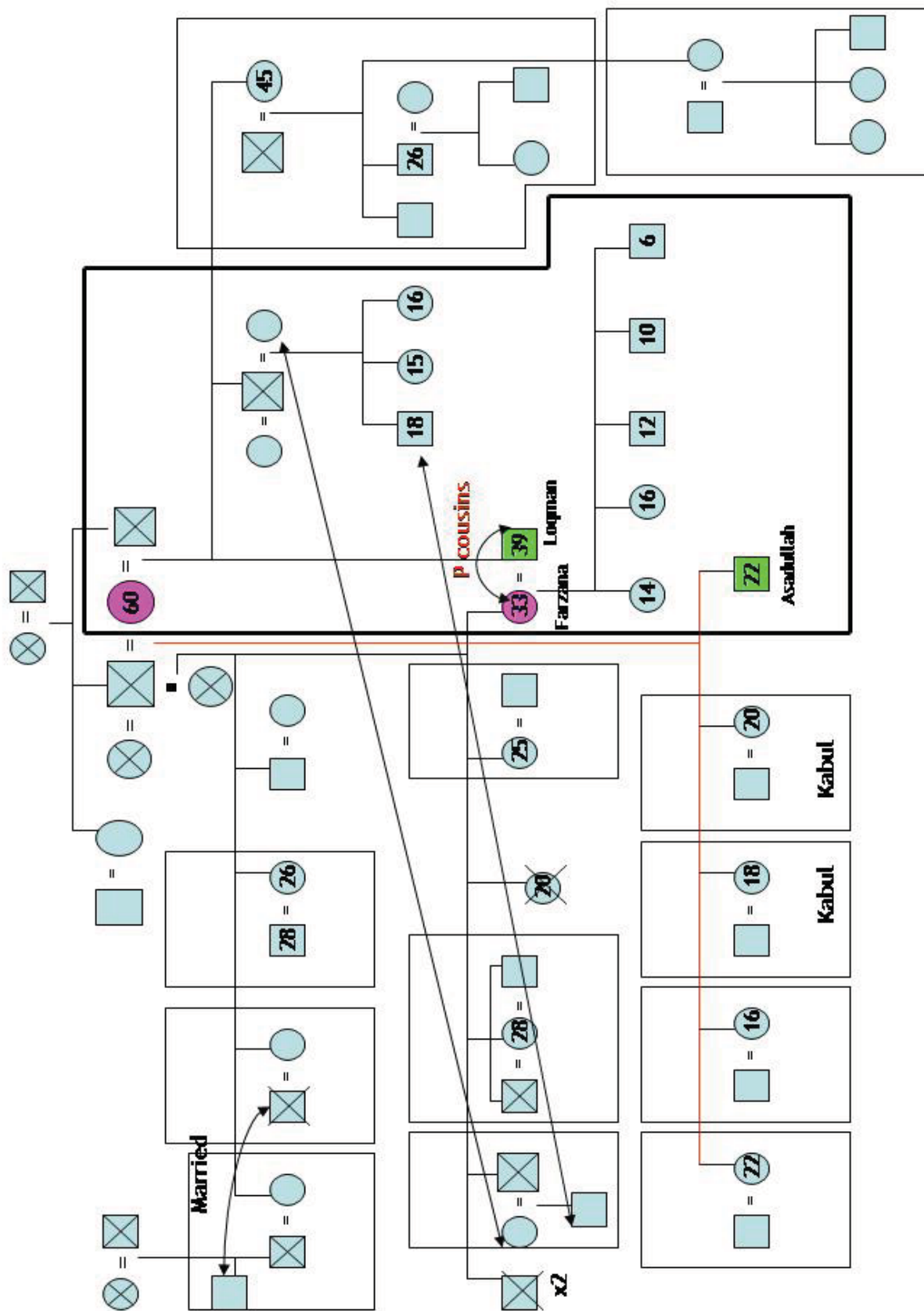

Map 20: Rural – Nangarhar Province – Haji Khoram Family

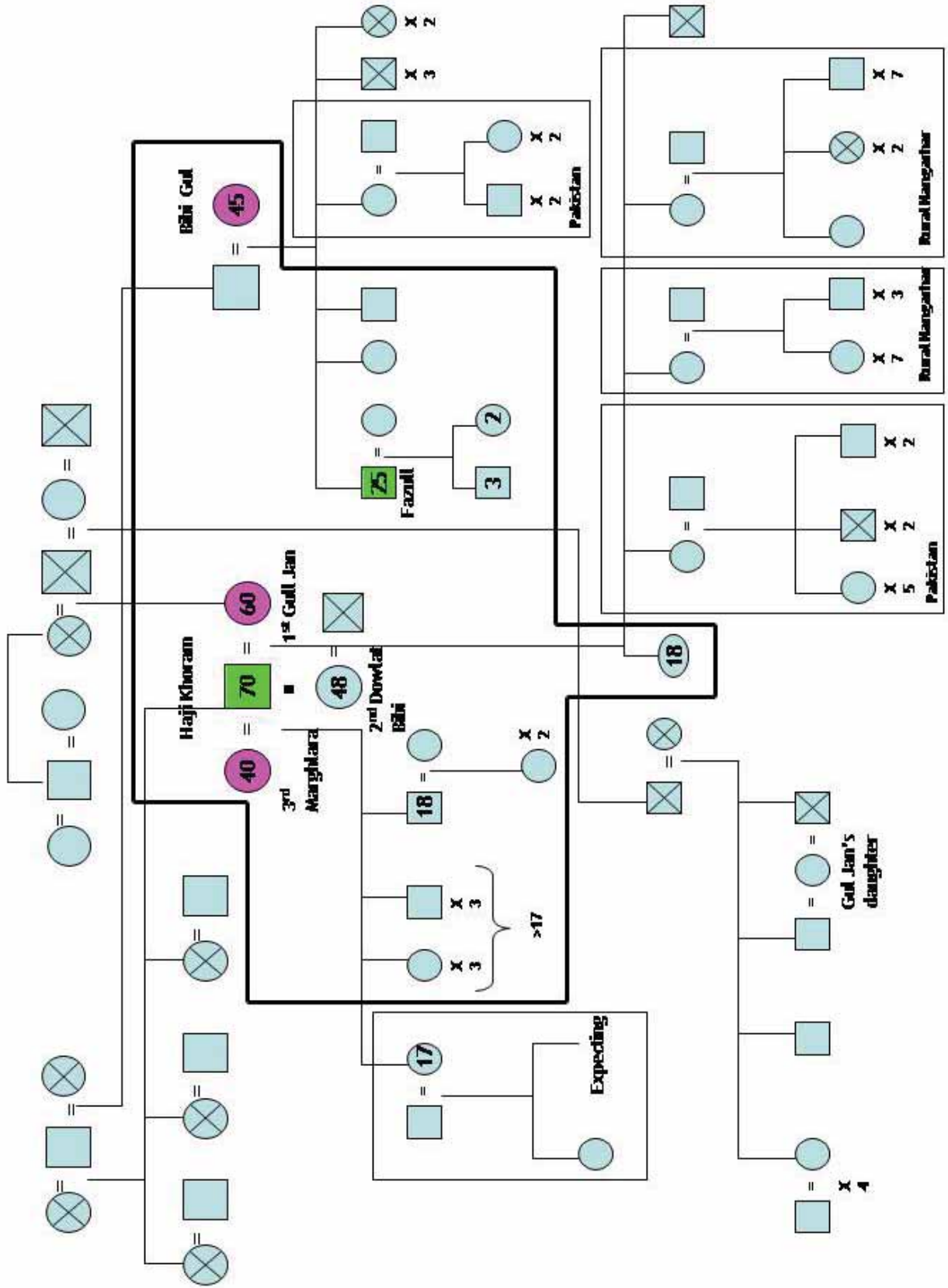

References

- Afghanistan News Centre, 8 March 2008, <http://www.afghanistannewscenter.com/news/march/mar82008.html>.
- Agarwal, B. "Bargaining and Gender Relations: Within and Beyond the Household." *Feminist Economics* 3, no. 1 (1997): 1-51.
- Amnesty International. "Afghanistan: Women Still Under Attack – A Systematic Failure to Protect." ASA 11/007/2005 (online), 2005.
- Becker, G.S. "Human Capital, Effort and the Sexual Division of Labour." *Journal of Labour Economics*, 3 (1985): S33-58.
- Becker, G.S. *A Treatise on the Family*. Cambridge, MA: Harvard University Press, 1981.
- Chant, S. *New Contributions to the Analysis of Poverty: Methodological and Conceptual Challenges to Understanding Poverty from a Gender Perspective*. Santiago: United Nations (Women and Development Unit, CEPAL), 2003.
- Chant, S. *Women and Survival in Mexican Cities: Perspectives on Gender, Labour and Low-Income Households*. Manchester: Manchester University Press, 1991.
- Folbre, N. "The Black Four of Hearts: Towards a New Paradigm of Household Economics." In *A Home Divided: Women and Income in the Third World*, edited by J. Bruce and N. Dwyer. Stanford, CA: Stanford University Press, 1988.
- Folbre, N. *Who Pays for the Kids? Gender and the Structures of Constraint*. London and New York: Routledge, 1994.
- Haugaard, M. *Power: A Reader*. New York: Manchester University Press, 2002.
- IRIN humanitarian news and analysis, 14 March 2007, <http://www.irinnews.org/report.aspx?reportid=70684>.
- Jackson, C. "Resolving Risk? Marriage and Creative Conjuality." *Development and Change* 38, no. 1 (2007): 107-109.
- Jacobsen, J.P. *The Economics of Gender*. Oxford: Blackwell, 1994.
- Kabeer, N. "Resources Agency and Achievements: Reflections on the Measurement of Women's Empowerment." *Development and Change*, 30 (1999): 435-464.
- Kabeer, N. *Reversed Realities: Gender Hierarchies in Development Thought*. London and New York: Verso, 1994.
- Klijn, F. and Pain, A. *Finding the Money: Informal Credit Practices in Rural Afghanistan*. Kabul: AREU, 2007.

Lukes, S. *Power: A Radical View*. London: Macmillan, 1974.

Moghadam, V. "Patriarchy in Transition: Women and the Changing Family in the Middle East." *Journal of Comparative Family Studies* 35, no. 2 (2004): 137-162.

Moore, H.L. *Feminism and Anthropology*. Cambridge: Polity Press, 1988.

Saito, M. *From Mohajer to Hamwatan: Afghans Return Home*. Kabul: AREU, 2007.

Sen, A. "Gender and Cooperative Conflicts." In *Persistent Inequalities: Women and World Development*, edited by I. Tinker. New York: Oxford University Press, 1990.

Sen, G., Germain, A. and Chen, L.C. (Eds). *Population Policies Reconsidered: Health, Empowerment, and Rights*. Boston: Harvard University (Harvard Centre for Population and Development Studies), 1994.

Smith, D.J. *Challenging Myths and Finding Spaces for Change: Family Dynamics and Family Violence in Afghanistan*. Kabul: AREU (forthcoming).

Smith, D.J. *Love, Fear and Discipline: Everyday Violence Toward Children in Afghan Families*. Kabul: AREU, 2008.

Smith, D.J. and Manalan, S. *Case Study: Community-Based Dispute Resolution in Nangarhar*. Kabul: AREU (forthcoming).

Tapper, N. *Bartered Brides: Politics, Gender and Marriage in an Afghan Tribal Society*. Cambridge: Cambridge University Press, 1991.

Yarshater, E. (Ed). *Encyclopedia Iranica Volume 1*. New York: Bibliotheca Persica Press, 2001.

Recent Publications from AREU

All publications are available for download at www.areu.org.af or from the AREU office in Kabul.

February 2009	The A to Z Guide to Afghanistan Assistance, Seventh Edition
January 2009	Delivering on Poverty Reduction: Focusing ANDS Implementation on Pro-Poor Outcomes, by Paula Kantor, Adam Pain, et al.
December 2008	Microcredit, Informal Credit and Rural Livelihoods: A Village Case Study in Balkh Province, by Erna Andersen and Amanda Sim
December 2008	"Let them Eat Promises": Closing the Opium Poppy Fields in Balkh and its Consequences, by Adam Pain
December 2008	Counter-Narcotics in Afghanistan: The Failure of Success?, by David Mansfield and Adam Pain
November 2008	A Mandate to Mainstream: Promoting Gender Equality in Afghanistan, by Anna Larson
November 2008	Elections in 2009 and 2010: Technical and Contextual Challenges to Building Democracy in Afghanistan, by Grant Kippen
November 2008	From Disappointment to Hope: Transforming Experiences of Young Afghans Returning "Home" from Pakistan and Iran, by Mamiko Saito
November 2008	Water Management, Livestock and the Opium Economy: Natural Resources Management, Farming Systems and Rural Livelihoods, by Alan Roe
October 2008	Afghanistan's Hidden Drug Problem: The Misuse of Psychotropics, by David Macdonald
October 2008	Opium Poppy and Informal Credit, by Adam Pain
August 2008	Factors Influencing Decisions to Use Child Labour: A Case Study of Poor Households in Herat, by Amanda Sim and Marie-Louise Høilund-Carlsen
August 2008	Factors Influencing Decisions to Use Child Labour: A Case Study of Poor Households in Rural Badakhshan, by Pamela Hunte and Anastasiya Hozyainova
August 2008	Afghanistan Research Newsletter 18
June 2008	How the Water Flows: A Typology of Irrigation Systems in Afghanistan, by Bob Rout

Afghanistan Research and Evaluation Unit

Flower Street (corner of Street 2)
Shahr-i-Naw, Kabul, Afghanistan

phone: +93 (0)79 608 548

email: areu@areu.org.af

website: www.areu.org.af
